

TECHNICAL MANUAL

**ORGANIZATIONAL, DIRECT SUPPORT, AND
GENERAL SUPPORT MAINTENANCE REPAIR
PARTS AND SPECIAL TOOLS LIST**

**(INCLUDING DEPOT MAINTENANCE REPAIR
PARTS AND SPECIAL TOOLS)**

FOR

**TEST FACILITY, ELECTRONIC
EQUIPMENT OQ-290(V)1/MSM**

(NSN 6625-01-095-9312)

**This publication is a courtesy quick copy from
the UNITED STATES ARMY PUBLICATIONS
CENTER, ST. LOUIS, MISSOURI, to meet your
needs while we are replenishing our regular
stock.**

HEADQUARTERS, DEPARTMENT OF THE ARMY

29 AUGUST 1983

ORGANIZATIONAL, DIRECT SUPPORT, AND GENERAL SUPPORT
MAINTENANCE REPAIR PARTS AND SPECIAL TOOLS LIST
(INCLUDING DEPOT MAINTENANCE REPAIR PARTS AND SPECIAL TOOLS)

FOR

TEST FACILITY, ELECTRONIC EQUIPMENT OQ-290(V)1/MSM

(NSN 6625-01-095-9312)

Current as of 10 March 1983

REPORTING ERRORS AND RECOMMENDING IMPROVEMENTS

You can help improve this manual. If you find any mistakes or if you know of a way to improve the procedures, please let us know. Mail your letter, DA Form 2028 (Recommended Changes to Publications and Blank Forms), or DA Form 2028-2 located in back of this manual directly to: Commander, US Army Communications-Electronics Command and Fort Monmouth, ATTN: DR-SEL-ME-MP, Fort Monmouth, NJ 07703.

In either case, a reply will be furnished directly to you.

	Page	Illus Figure
SECTION I. Introduction	1	
II. Repair Parts List	5	
GROUP 00 Test Facility, Electronic Equipment OQ-290(V)1/MSM.....	5	1
01 Van, Test Facility V-516(V)1/MSM.....	13	2
0101 Electrical Installation	23	3
010101 Raceway Installation (See next higher assembly for breakdown)		
01010102 Meter Box Assembly	29	4
01010103 Power Entrance Box	31	5
0101010301 Cable Assembly (See next higher assembly for breakdown)		
01010104 Air Conditioner (See TM 5-4210-308-25P or TM 5-4120-360-24P for parts)		
01010105 Paneling Installation (No parts authorized)		
0101010501 Van, Modification XM-995 (See TM 9-2330-363-24P for parts)		
010102 Shorting Probe Assembly (See next higher assembly for breakdown)		
010103 Fixture Assembly (See next higher assembly for breakdown)		
010104 Fixture Assembly (See next higher assembly for breakdown)		
010105 Fixture Assembly (See next higher assembly for breakdown)		
010106 Fixture Assembly (See next higher assembly for breakdown)		
010107 Cable Assembly (See next higher assembly for breakdown)		
010108 Alarm Box Assembly	33	6
0103 Emergency Light	35	7
0105 Telephone Set TA-312/PT (See TM 11-5805-201-20P and TM 11-5805-201-34P)		
0107 Intercommunication Station LS-147/FI (See TM 11-5830-21-24P for parts)		
02 Test Station AN/USM-410(V)2 (No parts authorized)		
03 Digital Card Tester AN/USM-465 (No parts authorized)		
04 Power Protection Assembly MX-2046/MSM (See TM 11-6130-415-24P)		
05 Cable Assembly, Electrical Power	37	8
06 Cable Assembly, Electrical Power, Stub.....	39	9
08 M10 Alarm (See TM 3-6625-2250-12)		

GROUP 09 M256 Detector (No parts authorized)
10 MI1 Decontamination Apparatus (No parts authorized)
13 Lantern (See next higher assembly for breakdown)
14 Digital Multimeter AN/USM-451 (See TM 11-6625-2953-40P for parts)
15 Oscilloscope OS-261C(V)1IU (See TM 11-6625-2735-24P for parts)
16 RF Millivoltmeter ME-5261USM (No parts authorized)
17 AMIFM Modulation Meter ME-5251USM (No parts authorized)
18 RF Signal Generator SG-10931U (See TM 11-6625-2780-24P for parts)
19 Power Meter ME-521/USM (See TM 11-6625-3007-24P for parts)
20 Power Sensor Head MX-103141USM (See TM 11-6625-3006-24P for parts)

SECTION III. Special Tools List (Not applicable)
IV. National Stock Number and Part Number Index.....40

SECTION I

INTRODUCTION

1. Scope

This manual lists spares and repair parts; special tool; special test, measurement, and diagnostic equipment (TMDE); and other special support equipment required for performance of organizational, direct support, and general support maintenance of the OQ-290(V)1/MSM. It authorizes the requisitioning and issue of spares and repair parts as indicated by the source and maintenance codes.

2. General

This Repair Parts and Special Tools List is divided into the following sections:

a. Section II. Repair Parts List. A list of spares and repair parts authorized for use in the performance of maintenance. The list also includes parts which must be removed for replacement of the authorized parts. Parts lists are composed of functional groups in numeric sequence, with the parts in each group listed in figure and item number sequence.

b. Section III. Special Tools List. Not applicable.

c. Section IV. National Stock Number and Part Number Index. A list, in National item identification number (NIIN) sequence, of all National stock numbers (NSN) appearing in the listings, followed by a list, in alphameric sequence, of all part numbers appearing in the listings. National stock numbers and part numbers are cross-referenced to each illustration figure and item number appearance.

3. Explanation of Columns

a. Illustration. This column is divided as follows:

(1) *Figure number.* Indicates the figure number of the illustration on which the item is shown.

(2) *Item Number.* The number used to identify item called out in the illustration.

b. Source, Maintenance, and Recoverability (SMR) Codes.

(1) *Source code.* Source codes indicate the manner of acquiring support items for maintenance, repair, or overhaul of end items. Source codes are entered in the first and second positions of the Uniform SMR Code format as follows:

<i>Code</i>	<i>Definition</i>
PA-	Item procured and stocked for anticipated or known usage.

<i>Code</i>	<i>Definition</i>
PD-	Support item, excluding support equipment, procured for initial issue or outfitting and stocked only for subsequent or additional replenishment.
PE-	Support equipment procured and stocked for initial issue or outfitting to specified maintenance repair activities.
XA-	Item is not procured or stocked because the requirements for the item will result in the replacement of the next higher assembly.
XB-	Item is not procured or stocked. If not available through salvage, requisition.
XC-	Installation drawing, diagram, instruction sheet, or field service drawing that is identified by manufacturer's part number. Item is not procured or stocked and cannot be requisitioned.
XD-	A support item that is not stocked. When required, item will be procured through normal supply channels.

NOTE

Cannibalization or salvage may be used as a source of supply for any items source coded above except those coded XA and aircraft support items as restricted by AR 700-42.

(2) *Maintenance code.* Maintenance codes are assigned to indicate the levels of maintenance authorized to USE and REPAIR support items. The maintenance codes are entered in the third and fourth positions of the Uniform SMR Code format as follows:

(a) The maintenance code entered in the third position will indicate the lowest maintenance level authorized to remove, replace, and use the support item. The maintenance code entered in the third position will indicate one of the following levels of maintenance:

<i>Code</i>	<i>Application/Explanation</i>
O-	Support item is removed, replaced, used at the organizational level.
F-	Support item is removed, replaced, used at the direct support level.
D-	Support items that are removed, replaced, used at depot, mobile depot, specialized repair activity only.

(b) The maintenance code entered in the fourth position indicates whether the item is to be repaired and identifies the lowest maintenance level with the capability to perform complete repair (i.e., all authorized maintenance functions). This position will contain one of the following maintenance codes:

<i>Code</i>	<i>Application/Explanation</i>
O-	The lowest maintenance level capable of complete repair of the support item is the organizational level.
F-	The lowest maintenance level capable of complete repair of the support item is the direct support level.
H-	The lowest maintenance level capable of complete repair of the support item is the general support level.
D-	The lowest maintenance level capable of complete repair of the support item is the depot level.
Z-	Nonreparable. No repair is authorized.

(3) *Recoverability code.* Recoverability codes are assigned to support items to indicate the disposition action on unserviceable items. The recoverability code is entered in the fifth position of the Uniform SMR Code format as follows:

<i>Recoverability Codes</i>	<i>Definition</i>
Z-	Nonreparable item. When unserviceable, condemn and dispose at the level indicated in position 3.
O-	Reparable item. When uneconomically repairable, condemn and dispose at organizational level.
F-	Reparable item. When uneconomically repairable, condemn and dispose at the direct support level.
D-	Reparable item. When beyond lower level repair capability, return to depot. Condemnation and disposal not authorized below depot level.

c. National Stock Number. Indicates the National stock number assigned to the item and will be used for requisitioning purposes.

d. Federal Supply Code for Manufacturer (FSCM). The FSCM is a 5-digit numeric code listed in SB708-41/42 which is used to identify the manufacturer, distributor, or Government agency, etc.

e. Part Number. Indicates the primary number used by the manufacturer (individual, company, firm, corporation, or Government activity) which controls the design and characteristics of the item by means of its engineering drawings, specifications, standards, and inspection requirements to identify an item or range of items.

NOTE

When a stock numbered item is requisitioned, the repair part received may have a different part number than the part being replaced.

f. Description. Indicates the Federal item name and, if required, a minimum description to identify the item.

g. Unit of Measure (U/M). Indicates the standard of the basic quantity of the listed item as used in performing the actual maintenance function. This measure is expressed by a two-character alphabetical abbreviation (e.g., ea, in, pr, etc). When the unit of measure differs from the unit of issue, the lowest unit of issue that will satisfy the required units of measure will be requisitioned.

h. Quantity Incorporated in Unit. Indicates the quantity of the item used in the breakout shown on the illustration figure, which is prepared for a functional group, subfunctional group, or an assembly.

4. Special Information

a. The following publications pertain to the OQ-290(V)1/MSM and its componets:

- TM 3-6625-2250-12, M10 Alarm.
- TM 5-4120-308-25P, Air Conditioner, Compact Vertical, 208V, 3 Phase, 50/60 Hz; 18,000 BTU Cooling, 12,000 BTU Heating (Keco Industries Inc, Model F18T-2).
- TM 5-4120-360-24P, Air Conditioner, Vertical, Compact Type 1, Vertical Size C, 18,000 BTU/HR, 208V, 3 Phase, 50/60 Hz (Keco Model F18T-2).
- TM 9-2330-363-24P, Van, Modification XM-995.
- TM 11-5410-216-14, Test Facility, Electronic Equipment OQ-290(V)1/MSM.
- TM 11-5805-201-20P, Telephone Set TA-3121 PT.
- TM 11-5805-201-34P, Telephone Set TA-3121 PT.
- TM 11-5830-221-24P, Telecommunication Station LS-147C/FI.
- TM 11-6130-415-24P, Power Protect Kit MX-20461MSM (To be published).
- TM 11-6625-2735-24P, Oscilloscope OS-261/U.
- TM 11-6625-2780-24P, Signal Generator SG-1112(V1)/U.
- TM 11-6625-2953-40P, Multimeter ANIUSM-451.
- TM 11-6625-3006-24P, Power Head Model M4240A, N421D, and N4226 (General Microwave) (To be published).
- TM 11-6625-3007-24P, Power Meter Model 475 (General Microwave Corp) (To be published).

b. National stock numbers that are missing

from P

source coded items have been applied for and will be added to this TM by future change/revision when they are entered in the Army Master Data File (AMDF). Until the NSN's are established and published, submit exception requisitions to: Commander, US Army Communications-Electronics Command and Fort Monmouth ATTN: DR-SEL-MM, Fort Monmouth, NJ 07703 for the part required to support your equipment.

5. How to Locate Repair Parts

i When NSN or part number is unknown.

(1) *First*. Using the table of contents, determine the functional group within which the item belongs. This is necessary since illustrations are prepared for functional groups and listings are divided into the same groups.

(2) *Second*. Find the illustration covering the functional group to which the item belongs.

(3) *Third*. Identify the item on the illustration and note the illustration figure and item number of the item.

(4) *Fourth*. Using the Repair Parts Listing, find the figure and item number noted on the illustration.

b. *When NSN or part number is known.*

(1) *First*. Using the Index of National Stock Numbers and Part Numbers, find the pertinent NSN or part number. This index is in NIIN sequence followed by a list of part numbers in alphameric sequence, cross-referenced to the illustration figure number and item number.

(2) *Second*. After finding the figure and item number, locate the figure and item number in the repair parts list.

6. Abbreviations

Not applicable.

(Next printed page is 4.1.)

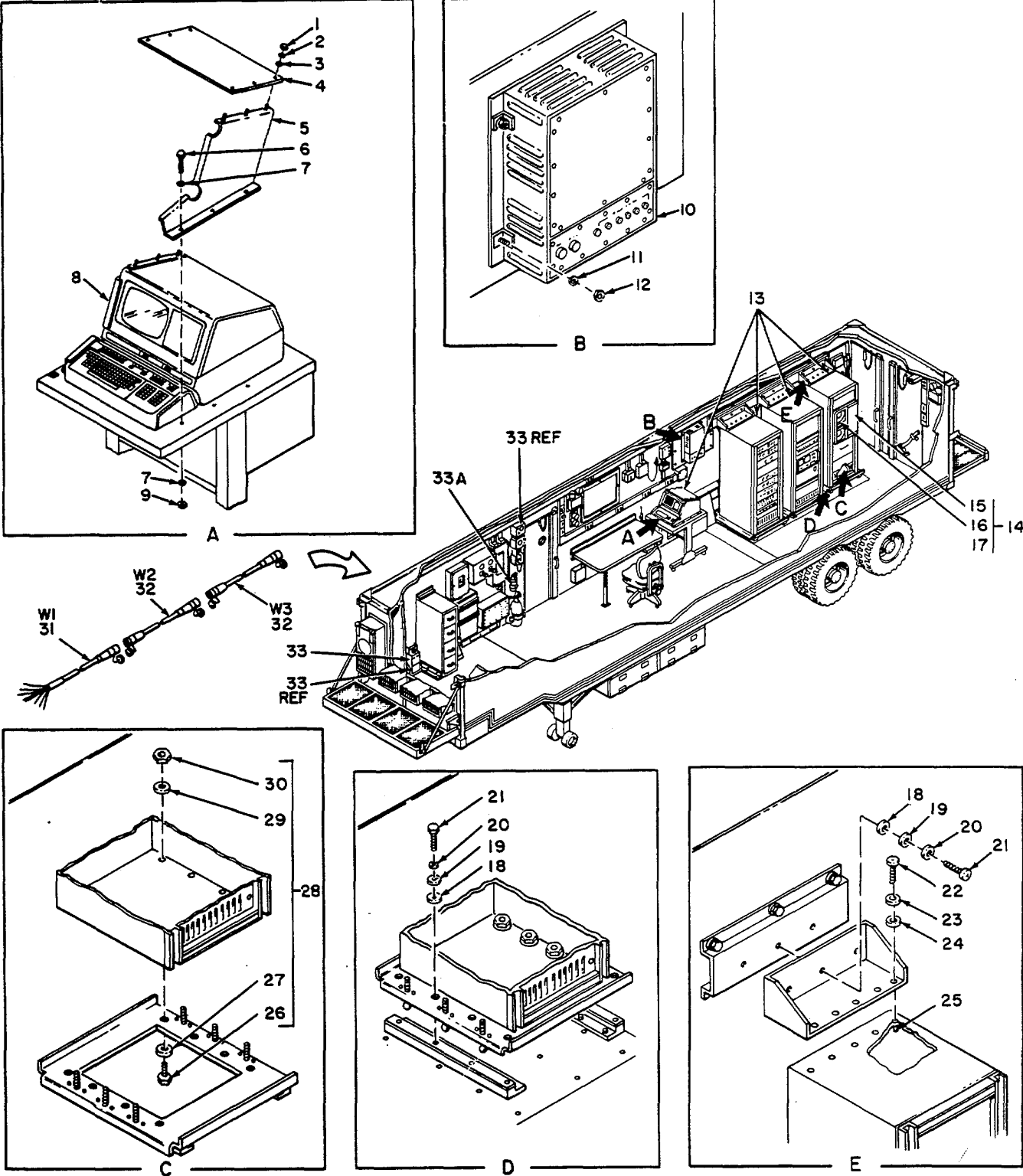

NOTE:
PREFIX ALL REFERENCE
DESIGNATIONS WITH AI

EL6XP033

Figure 1. Test Facility, Electronic Equipment OQ-290(V)/MSM (Sheet 1 of 2).

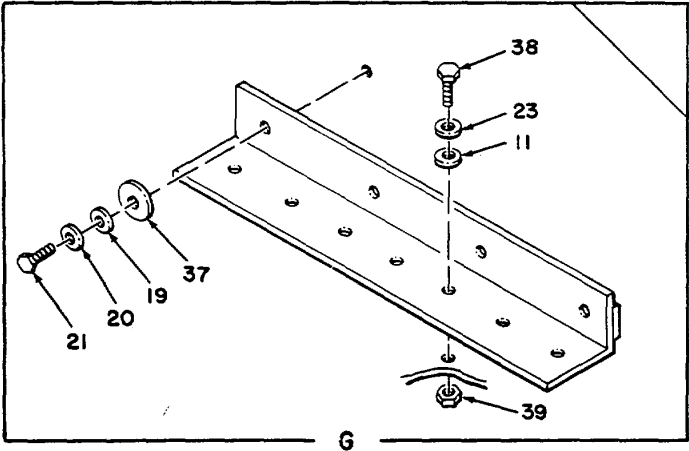
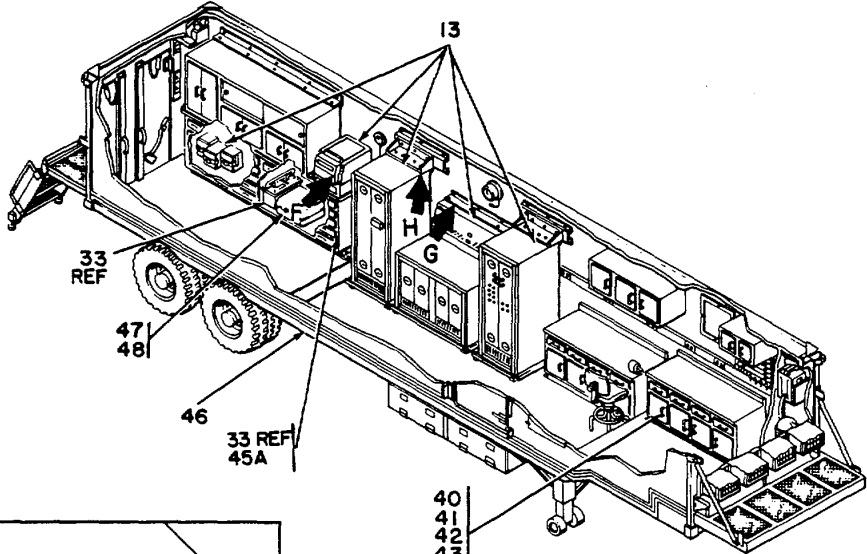
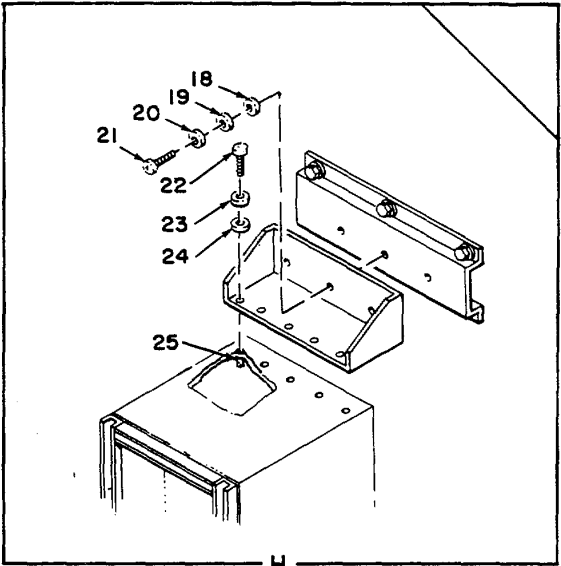
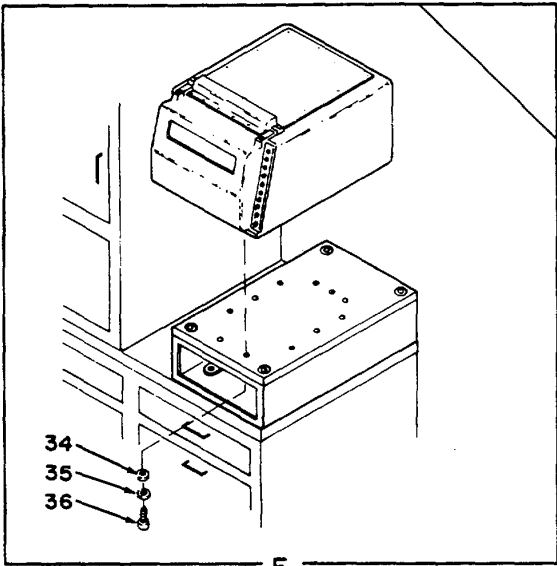

EL6XP034

Figure 1. Test Facility, Electronic Equipment OQ-290(V)/MSM (Sheet 2 of 2).

(1) ILLUSTRATION		(2)	(3)	(4)	(5)	(6) DESCRIPTION	(7)	(8)
(a) FIG NO.	(b) ITEM NO.	SMR CODE	NATIONAL STOCK NUMBER	FSCM	PART NUMBER	USABLE ON CODE	U/M	QTY INC IN UNIT
						GROUP 00 TEST FACILITY 0Q-290IVI/MSM		
1	1	PAFZZ	5310-00-934-9751	96906	MS35650-302	NUT PLAIN,HEXAGON	EA	6
1	2	PAFZZ	5310-00-045-3296	96906	MS35338-43	WASER,LOCK	EA	6
1	3	PAFZZ	5310-00-014-5850	96906	MS27183-42	WASHER,FLAT	EA	6
1	4	XDFZZ		56996	B4008492	PLATE, TOP	EA	1
1	5	XDFZZ		56996	B4008490	SUPPORT ASSY,RAIGHT	EA	1
1	6	PAFZZ	5305-00-269-3220	96906	MS90725-70	SCREW,CAP,HEXAGON H.....	EA	6
1	7	PAFZZ	5310-00-081-4219	96906	MS27L83-t2	WASHER,FLAT	EA	3
1	8	XDFZZ		56996	84008491	SUPPORT ASSY.LEFT	EA	11
1	9	PAFZZ	5310-00-984-3806	96906	MS51922-9	NUT.SELF-LOCKING H.....	EA	16
1	10	PA0D0	6625-01-098-6956	80058	MK-2046/1NS	POWER,PROTECT KT	EA	1
1	11	PA0ZZ	5310-00-582-5677	96906	MS15795-810	WASHER.FLAT	EA	4
1	12	PA0ZZ	5310-00-929-1807	96906	MS51922-2	NUT.SELF-LOCKING.HE	EA	4
1	13	PD00D	6625-01-069-4223	80058	AN/US-4100(V)2	TEST STATION,ELECTR	EA	1
1	14	XBFZZ		56996	84005347	TRANSPORTATION KIT	EA	1
1	15	XOFZZ		56996	84005342	SLEEVE.....	EA	24
1	16	XDFZZ		56996	84005343	STRAP ASSY	EA	
1	17	XOFZZ		56996	84005338	VERTICAL RESTRAINT.	EA	2
1	18	PAFZZ	5970-01-050-4Z07	80063	SC-8-681043	INSULATOR,BUSHNG	EA	67
1	19	PAFZZ	5310-01-052-5837	80063	5C-8-681044	WASHER,FLAT	EA	67
1	20	PAFZZ	5310-00-974-6623	96906	MS35338-140	WASHER,LOCK	EA	18
1	21	PAFZZ	5306-00-727-4578	96906	MS35307-339	BOLT,MACHINE	EA	67
1	22	PAFZZ	5306-00-543-4405	96906	MS35307-334	BOLT,MACHINE	EA	25
1	23	PAFZZ	5310-00-933-8121	96906	MS35338-139	WASHER,LOCK	EA	11
1	24	XOFZZ		96909	MS16212-12	WASHER,FLAT	EA	25
1	25	PAFZZ		96906	MS27130-43	NUT,BLIND RIVET	EA	25
1	26	PAFZZ	5305-00-685-3509	96906	MS35308-362	SCREW,CAP,HEXAGON H.....	EA	40
1	27	XDFZZ		96906	MS16212-13	WASHER,FLAT	EA	40
1	28	XBFZZ		56996	8400532T	INSTALLATION KIT.....	EA	1
1	29	PAFZZ	5310-00-984-7042	96906	M535338-141	WASHERLOCK	EA	40
1	30	PAFZZ	5310-00-245-3612	96906	NS35650-3384	NUT,PLAIN,HEXAGON	EA	4
1	31	PAFOO	5995-01-133-9992	80063	SC-D-883964G92	CABLE ASSEMBLYPO	EA	1
1	32	PAFOO	5995-01-134-3159	80063	SC-D-883963C93	CABLE ASSEMBLY,POWE	EA	2
1	33	XDODD		80058	M10	ALARN,CHEM AGENT	EA	1
1	34	PAFZZ	5310-00-550-5054	96906	MS15795-809	WASHER,FLAT	EA	11
1	35	PAFZZ	5310-00-933-8121	96906	MS35338-139	WASHER,LOCK	EA	11
1	36	PAFZZ	5305-00-702-4523	96906	MS35307-306	SCREW,CAP,NEXAGON	EA	11
1	37	PAFZZ	5970-00-050-4207	80063	SC-B-681043	INSULATOR,BUSHING	EA	4
1	38	PAFZZ	5305-00-685-3511	96906	MS35308-306	SCREW,CAP,HEXAGON H.....	EA	7
1	39	PAFZZ	5310-00-400-5503	96906	MS35650-3254	NUT.PLAIN,HEXAGON	EA	7

SECTION II

TM 11-5410-216-24P

(1) ILLUSTRATION		(2)	(3)	(4)	(5)	(6) DESCRIPTION	(7)	(8)
(a) FIG NO.	(b) ITEM NO.	SMR CODE	NATIONAL STOCK NUMBER	FSCM	PART NUMBER	USABLE ON CODE	U/M	QTY INC IN UNIT
1	40	PAOHO	6625-01-099-7065	80058	ME-521IUSM	POWER METER ASSEMB	EA	1
1	41	PAOHO		80058	ME-525/USN	AFN HUD MTR	EA	1
1	42	PAODD		80058	NE-526/USN	RF MILLIVOLTMETER	EA	1
1	43	PAOHO	6625-01-119-7314	80058	S--61CVIL/U	OSCILLOSCUPE	EA	1
1	44	PAOHO	6625-01-060-6804	80058	AN/USM-451	MULTIMETER	EA	1
1	45	PAOHO	6625-01-100-3726	80058	NX-10314/USN	THERMOSTAT,POWER SE	EA	1
1	46	XADDD		80058	V-516(V11 SN	VAN,TEST, FAC	EA	1
1	47	PDDDD	6625-01-126-2473	80058	AN/USMI65A	TEST SET,DIGITAL CA,	EA	1
	48	PAOHD	6625-00-318-6304	80058	SG-1093/U	GENERATOK.SIGNAL	EA	1
					6/(7 BLANK)			

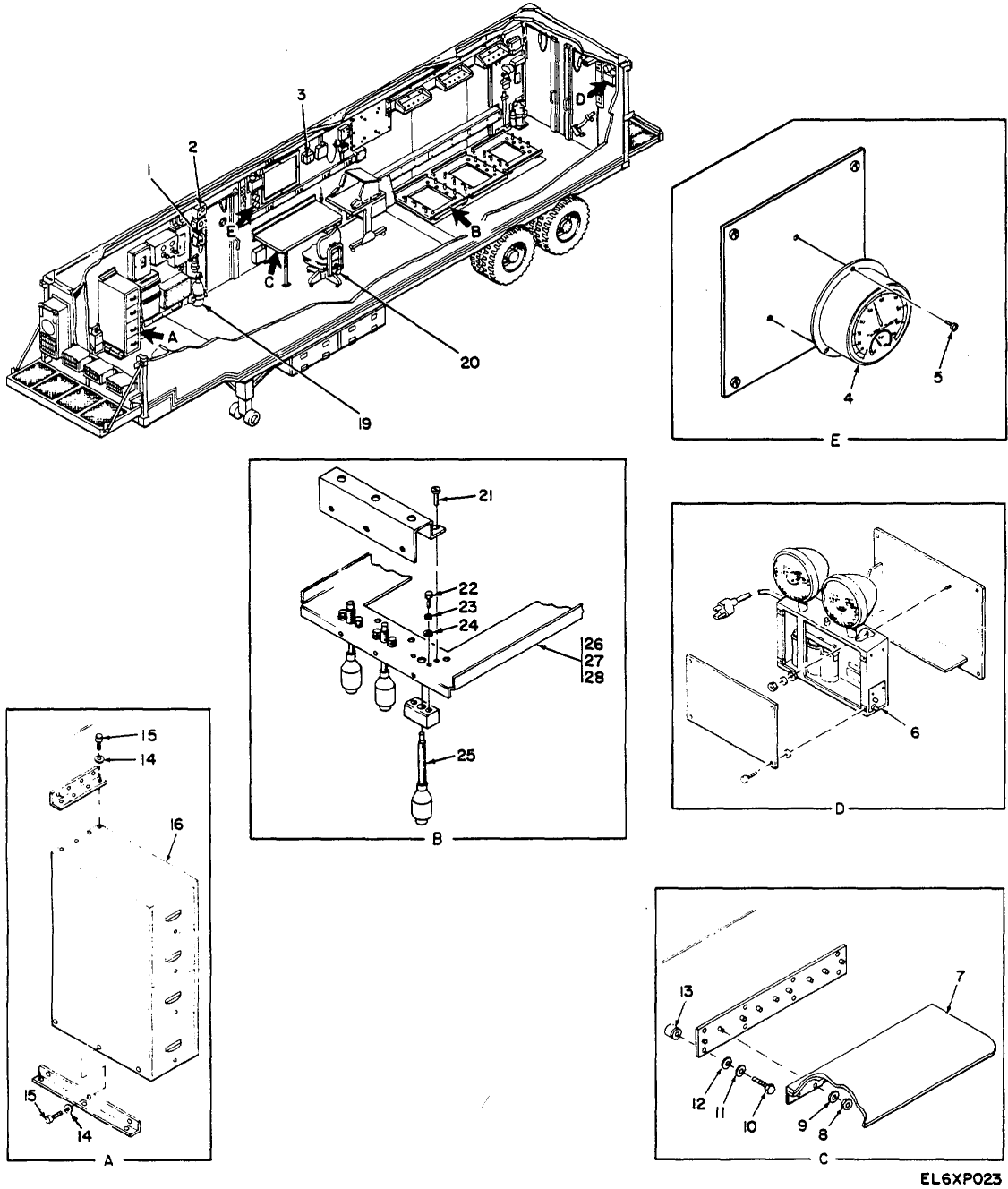
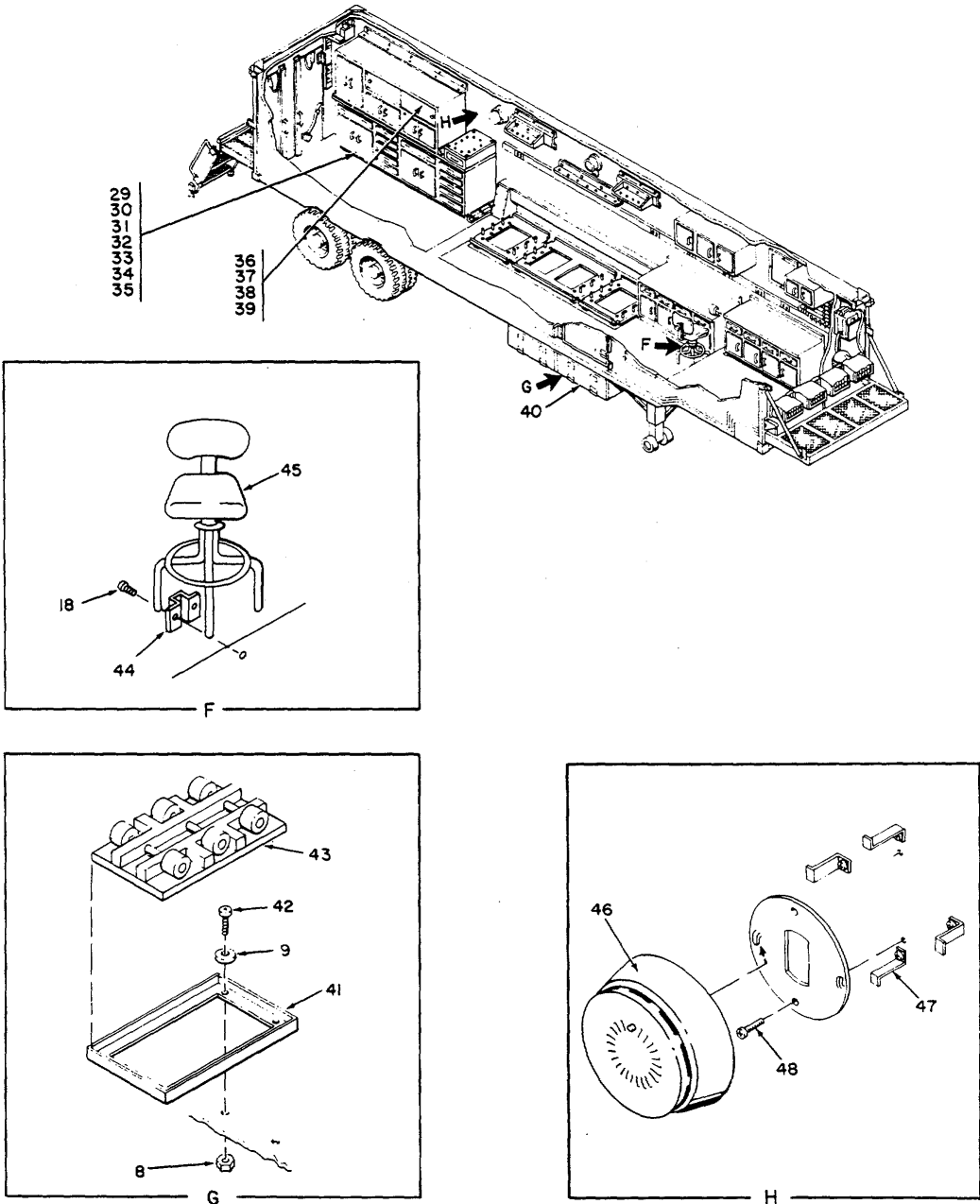

Figure 2. Van, Test Facility V-516(V)1/MSM (Sheet 1 of 5).



EL6XP022

Figure 2. Van, Test Facility V-516(V)1/MSM (Sheet 2 of 5).

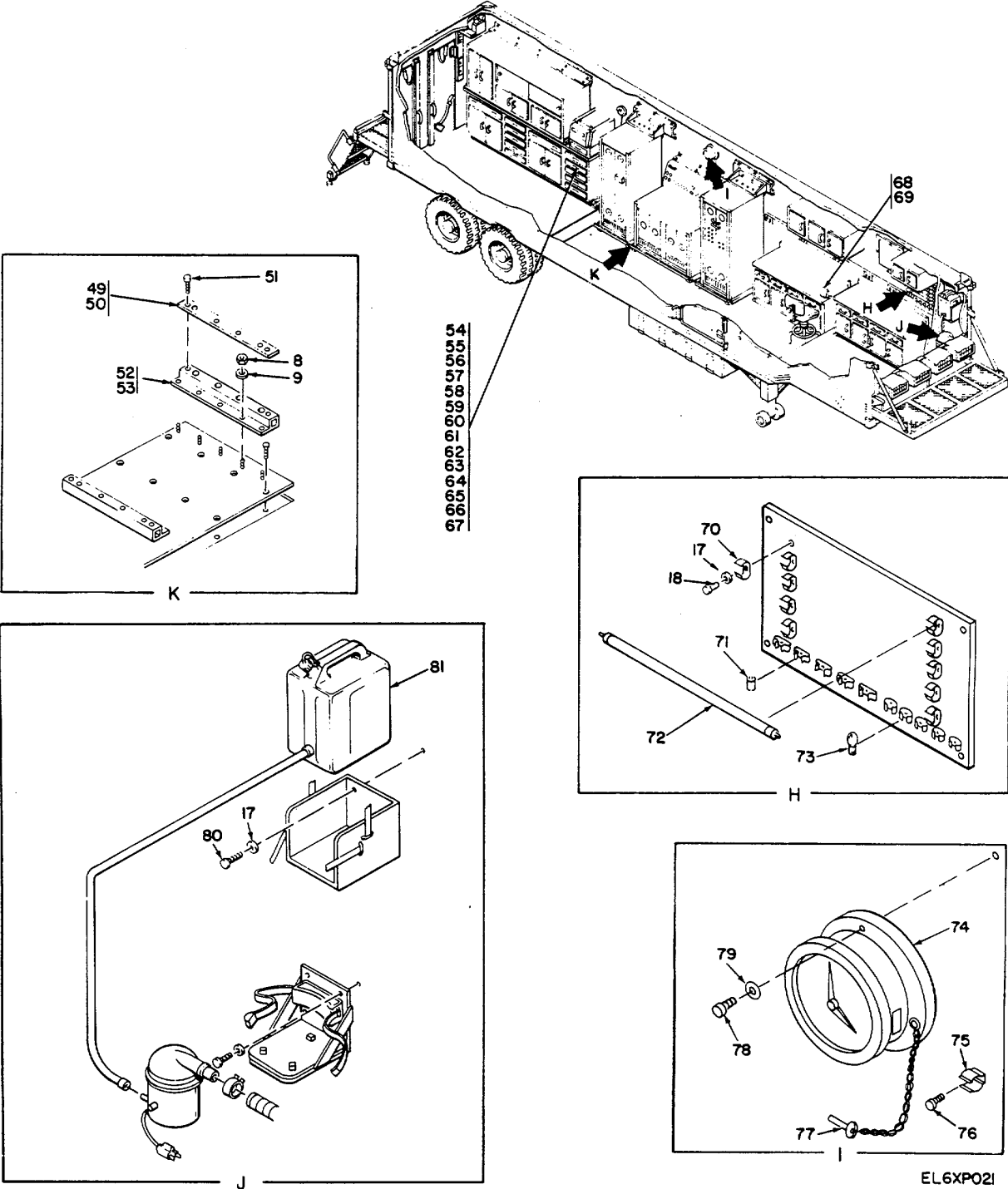
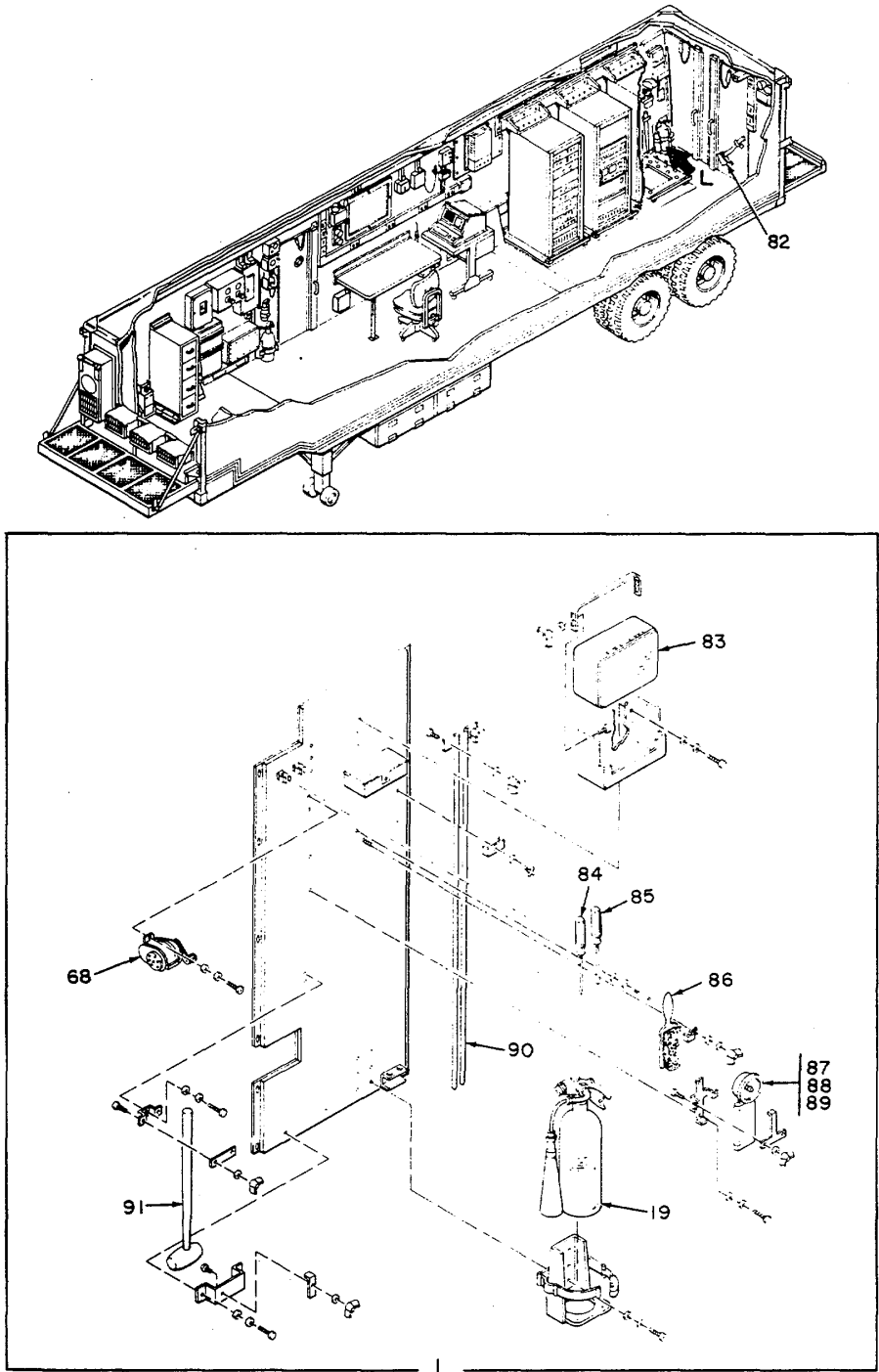

Figure 2. Van, Test Facility V-516(V)/MSM (Sheet 3 of 5).



EL6XP020

Figure 2. Van, Test Facility V-516(V)/MSM (Sheet 4 of 5).

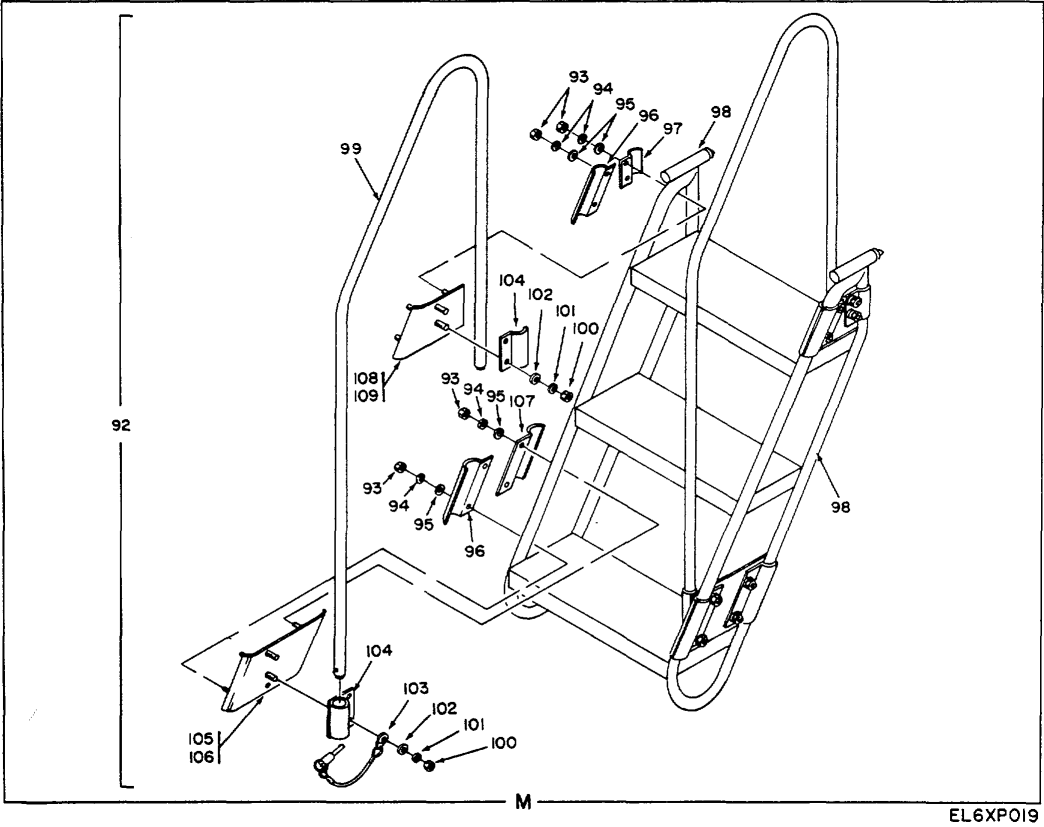
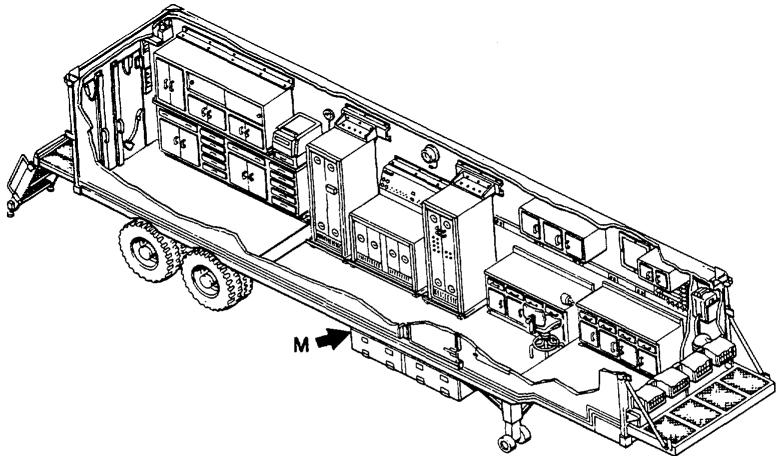

Figure 2. Van, Test Facility V-516(V)/MSM (Sheet 5 of 5).

(1) ILLUSTRATION		(2)	(3)	(4)	(5)	(6) DESCRIPTION	(7)	(8)
(a) FIG NO.	(b) ITEM NO.	SMR CODE	NATIONAL STOCK NUMBER	FSCM	PART NUMBER	USABLE ON CODE	U/M	QTY INC IN UNIT
						GROUP 01 VAN, TEST FACILITY V-516(V)11/MSM		
2	1	PDOFD	5805-00-543-0012	80058	TA-312/PT	TELEPHONE SET	EA	1
2	2	PDOHF	5830-01-008-3126	80058	LS-147F/F1	INTERCOMMUNICATION	EA	1
2	3	PAOZZ	6685-00-087-5499	92578	W42AA-L	CONTROL,HUMIDITY	EA	1
2	4	PAOZZ		93101	HTA-169	HGYCONETER	EA	1
2	5	PAOZZ		96906	MSS1861-39	SCREW,TAPPIN G THREAS	EA	3
2	6	PAOOO		80538	CC-2BHSRS-CPN	EMERGENCY LIGHTING	EA	2
2	7	XOOZZ		56996	84008149	OKOP LEAP TABLE	EA	1
2	8	PAOZZ	5310-00-929-1807	96906	NS51922-2	NUT,SELF-LOCKING,HEH	EA	145
2	9	PAOZZ	5310-00-550-5054	96906	NS15795-809	WASHER,FLAT	EA	145
2	10	PAOZZ	5306-00-816-5272	96906	MS35307-340	MACHINE BOLT	EA	41
2	11	PAOZZ	5310-00-974-6623	96906	1S35338-140	WASHER,LOCK	EA	11
2	12	PAFZTZ	5310-00-625-5756	96906	SIS795-812	WASHER,FLAT	EA	140
2	13	XDOZZ		56996	14008322-02	SPACER	EA	3
2	14	PAOZZ	5310-00-809-4058	96906	MS27183-LO	WASHER,FLAT	EA	71
2	15	PAOZZ	5305-00-993-2459	96906	M535207-283	SCREW,MACHIINE	EA	7
2	16	XDOZZ		56996	84008679-001	FILE CABINET,MOD	EA	1
2	17	PAFZZ	5310-00-883-9384	96906	SSIST95-842	WASHER,FLAT	EA	4C
2	18	PAOZZ	5305-00-497-7410	96906	MSSL861L-53C	SCREW.TAPPING.THREA	EA	4
2	19	XDDZF	4210-00-270-4512	80063	SC--39482	EXTINGUISHER.FIRE,O	EA	1
2	20	XDOZF	7110-01-094-5655	80063	SC-0-53955L	CHAIR,ROTARY	EA	1
2	21	PAOZZ	5305-00-432-4170	96906	H551861-35	SCREW TAPPING.THREA	EA	100
2	22	PAOZZ	5305-00-576-5807	96906	MS35307-3LI	SCREW,CAP,HEXAGON H	EA	12
2	23	PAOZZ	5310-00-933-8121	96906	MS35338-L39	WASHER,LCK	EA	1
2	24	PAOZZ	5316-00-582-5677	96906	M515795-910	WASHER,FLAT	EA	1
2	25	PAOZZ		56996	8008441	CASTER AND SCREW AS	EA	6
2	26	XDOZZ		56996	8008361	PLATE MTG ASSY	EA	1
2	27	XDOZZ		56996	84008362	PLATE MTG ASSY	EA	1
2	28	XDOZZ		56996	84008363	PLATE ITG ASSY	EA	1
2	29	XDOOO		81348	#-L-312TYPE3	LAMP DESK	EA	1
2	30	PAOZZ	6240-00-152-2982	08806	FILSTCW	LAMP. FLUURESSENT	EA	1
2	31	XO000		81348	WL-312TYPE1CL2	DROP LIGHT	EA	1
2	32	PADZZ		08806	6OW	LAMP, VACUM	EA	1
2	33	PE000	5180-00-064-5118	80058	TK-101/G	TOOL KIT,ELECTRONIC	EA	1
2	34	XO000	5180-00-610-8177	80058	TK-105/G	TOOL KIT,ELECTRONIC	EA	1
2	35	XDOZZ		80112	9200	TOOL KIT,ALIGNMNT	EA	2
2	35A	XDOZZ		80063	SM-D-350218	VAC CLEANER	EA	1
2	36	PADZZ		52942	2064	STRAP,WRIST,STATIC	EA	1
2	37	XDDZZ		76381	8210	TABLE NAT.STATIC	EA	1

SECTION II

TM 11-5410-216-24P

(1) ILLUSTRATION		(2)	(3)	(4)	(5)	(6)	(7)	(8)
(a) FIG NO.	(b) ITEM NO.	SMR CODE	NATIONAL STOCK NUMBER	FSCM	PART NUMBER	DESCRIPTION USABLE ON CODE	U/M	QTY INC IN UNIT
2	38	PAOZZ		89942	01-222-H7	LEVEL,24 IN	EA	1
2	39	PAOZZ		56996	SC-8-539492	STRAP.GROUNCE	EA	2
2	40	XDOZZ		56996	54008109	JACK ASSY	EA	1
2	41	XDOZZ		56996	84008467	DOLLY STORAGE RACK	EA	2
2	42	PAOZZ	5305-00-719-5021	96906	51959-81	SCREW,MACHINE	EA	8
2	43	XOFZL		56996	840084L8	OOLLY ASSY	EA	2
2	44	XDOZZ		56996	84008488	CLAP,CHAIR	EA	2
2	45	XDCZZ		81348	AA-C-00295CL253	CHAIR,DRAFTERS	EA	1
2	46	PAFZZ		50996	84008757	SMOKE DETELTLR	EA	1
2	47	XDCZZ		56996	84008775	STRAP.SUPPCT	EA	4
2	48	XDFZZ		9690b	W551861-14	SCREW,TAPPING,THREA	EA	4
2	49	XDCZZ		56996	84008043-002	INSULATOR,STRIP	EA	2
2	50	XDCZZ		56996	84008043-001	INSULATOR,STRIP	EA	10
2	51	PAOZZ	5306-00-721-4578	969060	S35307-339	BULT,NACHINE I	EA	6
2	51A	PAGZZ	5970-01-050-4207	80063	SC-8-681043	INSULATOR.8USING	EA	67
2	52	XDOZZ		56996	B4008079	SUPPORT BASE ELECT	EA	10
2	53	XDOZZ		56996	84008041	SUPPORT BASE ELECT	EA	2
2	54	PEOZZ	5120-00-829-769L	89750	0E5-S	WRENCH SET,OPEN END	EA	1
2	55	PEOZZ	5120-00-184-8447	6584	1120	WRENCH, OPEN END	EA	1
2	56	PEOZZ	5120-00-277-8309	47805	PROT03215	WRENCH,OPEN END	EA	1
2	57	PEOZZ	5120-00-184-8443	65814	111iLL4	RENCH,OPEN ENC	EA	1
2	58	PEOZZ		65d52	#-604	SOCKET 1-8	EA	1
2	59	PEOZZ		65852	M-605	SOCKET 5-32	EA	1
2	60	PEOZZ	5120-00-449-8083	11599	AT503	WRECHAJUSTAB	EA	1
2	61	PEOZZ	5120-00-942-3928	70925	529-0	SOCKET,5/32	EA	1
2	62	PEOZZ	5120-00-089-363	96508	PS120	WRENCH SET.SCKET	EA	1
2	63	PEOZZ	5120-01-019-0803	71468	CET-OL-2	REMNOVAL TOOL,CONNEC	EA	1
2	64	PEOZZ	5120-01-036-3728	96508	SDX-22	SCREWORIVER SET,CR	EA	1
2	65	PEOZZ	5120-01-019-0819	71468	CCT-OL	CRIMPING TO nL,TERNL	EA	1
2	66	PEOZZ		81348	GGG-W64iTYP4CL5	ADAPTER 3/8X4	EA	1
2	67	PEOZZ		81348	GGGS-686TYP3CL2	TORQUE WRENCH	EA	1
2	68	XDOZZ	7520-00-162-6178	80063	SC-C-539503	SHARPENER,PENCIL	EA	1
2	69	PAOZZ	5305-00-517-6323	96906	SS5186L-39C	SCREI,TAPPING.THREA	EA	
2	70	XOOZZ		80063	C-C-539529-1	CLIPSPRING	EA	20
2	71	PADZZ	6250-00-194-4794	80063	SC-8-39504	STAREK. FLUGRESCENT	EA	5
2	72	PADZZ	6240-00-152-2996	80063	SC-C-539495	LA,P, FLUORESCEN	EA	5
2	73	PAOZZ		08806	25T8OC	LAMP, INCADESCENT	EA	5
2	74	PAOZZ		81349	MIL-C-II49TYPE A	CLOCK	EA	1
2	75	PAOZZ	5999-00-879-6320	81349	M24066/2-304	CLIP, ELECTRICAL	EA	1

SECTION II

TM 11-5410-216-24P

(1) ILLUSTRATION		(2)	(3)	(4)	(5)	(6)	(7)	(8)
(a) FIG NO.	(b) ITEM NO.	SMR CODE	NATIONAL STOCK NUMBER	FSCM	PART NUMBER	DESCRIPTION USABLE ON CODE	U/M	QTY INC IN UNIT
2	76	PAOZZ		96906	NSS5186L-17	SCREW4ACNE	EA	1
2	77	XOZZ		56996	84008466	KEY ASSY	EA	1
2	78	PAOZZ	305-00-137-3033	96906	NS51861-27C	SCREI,TAPPING, THREA	EA	3
2	79	PAOZZ	5310-00-983-8483	96906	MS27183-5	WASHER,FLAT	EA	2
2	80	PAOZZ	5305-00-619-7712	96906	M551861-SIC	SCREW, TAPPING, THREA	EA	1
2	81	PAOZZ		56996	84008374	HUMIDIFIER ASSEL	EA	1
2	82	XDOZZ	5110-00-115-5049	80063	SC-C-539451	AX,SINGLE BIT	EA	1
2	83	XDWZZ		80063	SC-0-681425	FIRST AID KIT	EA	1
2	84	PEOZZ	5120-00-240-8716	80063	SC-C-539894	SCREWDRIVER,CKOSS T	EA	1
2	85	PEOZZ	5120-00-451-8250	80063	SC-C-539502	SCREODRIVIR	EA	1
2	86	XDOZZ	7920-00-178-8315	80063	SC-C-539469	BRUSH,OUSTINGCBENCH	EA	1
2	87	PAOOO	6230-00-729-96L4	32532	2106-7	FLASHLIGHT	EA	1
2	88	PAOZZ	6240-00-155-7786	08806	PR2	LAHP, INCANDESCENT	EA	1
2	89	PAOZZ	6135-01-103-6514	90303	SIZE O	SATTERY.MECURY	EA	4
2	90	XDOZZ		80063	SC-D-14158	ROD,GROUND NX-348/G	EA	2
2	91	XOOZO	5120-01-110-9193	16732	8D-8	HANMER,HAND	EA	1
2	92	XDFZZ		56996	84008745	LADOER ASSY	EA	1
2	93	PAFZZ	5310-00-Z50-9477	96906	11S35o49-2254	hUT.PLAIN,htXAGC4	EA	16
2	94	PAFZZ	5310-00-933-8121	96906	MS35338-139	WASHER,LOCK	EA	16
2	95	PAFZZ	5310-00-582-5677	96906	S1795-810	ASHER.FLAT	EA	16
2	96	XFZZ		56996	84008726	CLIP.LAOOER.IGHT	EA	3
2	97	XOFZZ		56996	84008752	CLIP,TOP,LADCER	EA	2
2	98	XOFZZ		19207	11684608	LADDER	EA	1
2	99	XDFZZ		56996	84008746	HANDRAIL	EA	1
2	100	PAFZZ		96906	M535649-2316	NUT.PLAIN.HEXAGON	EA	8
2	101	PAFZZ	5310-00-974-6623	96906	MS35338-140	WASHER,LOCK	EA	8
2	102	PAFZZ	5310-00-625-5756	96906	1151S795-812	WASHER.FLAT	EA	8
2	103	PAFZZ		56996	84008764	PIN AND LANYARD ASY	EA	2
2	104	XDFZZ		56996	84008153	PLATE.HANDRAIL	EA	4
2	105	XDFZZ		56996	84008749	LADDER PLATE,OT	EA	1
2	106	XOFZZ		56996	84008750	LAOCER PLATEBOT	EA	1
2	107	XDFZZ		56996	84008751	CLIP,LADOER,LEFT	EA	3
2	108	XDFZZ		56996	840087471	LADDER,PLATE,TOP LE	EA	1
2	109	XOFZZ		56996	84008748	LADUEK PLATE,TOP RI	EA	1

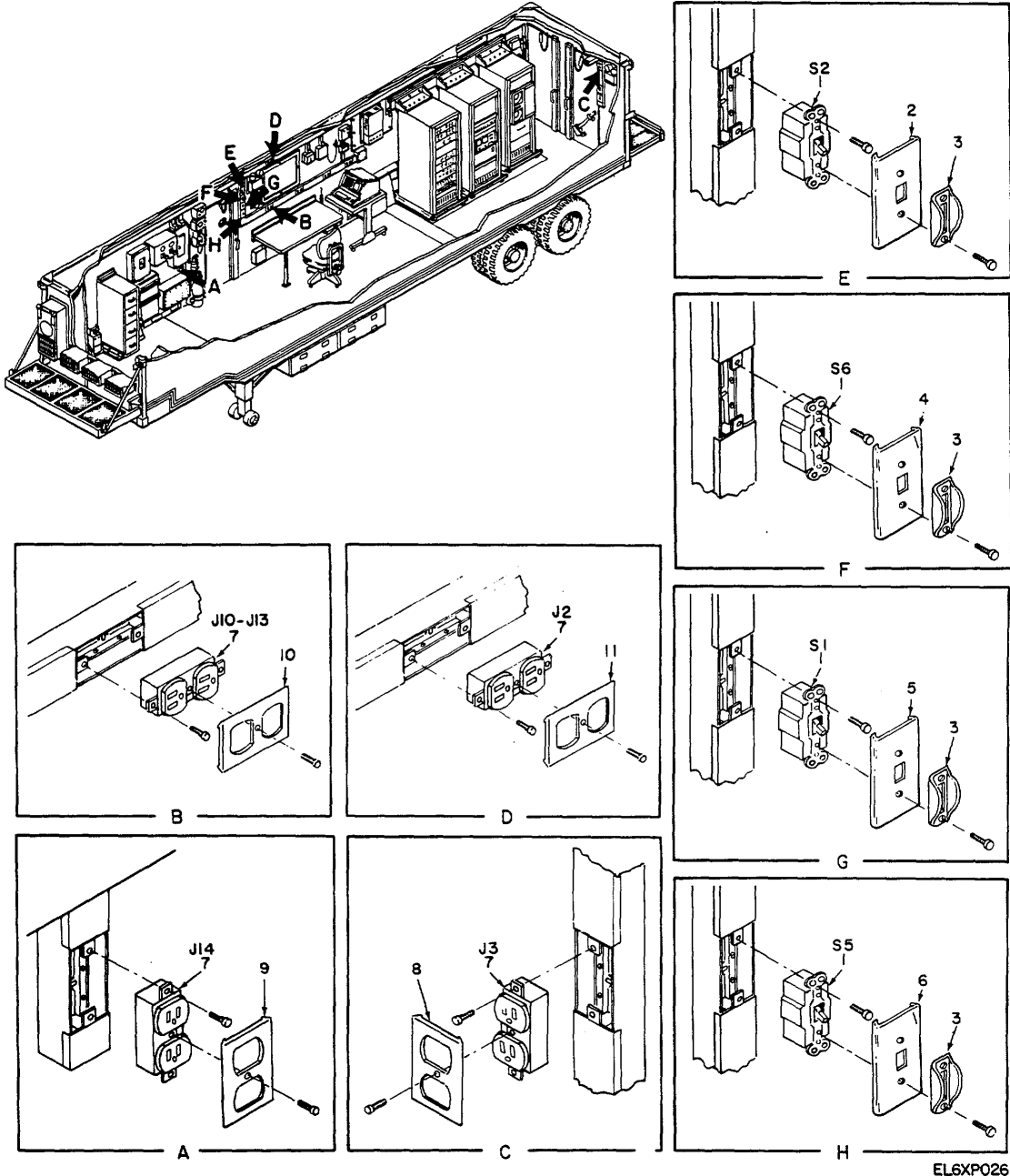

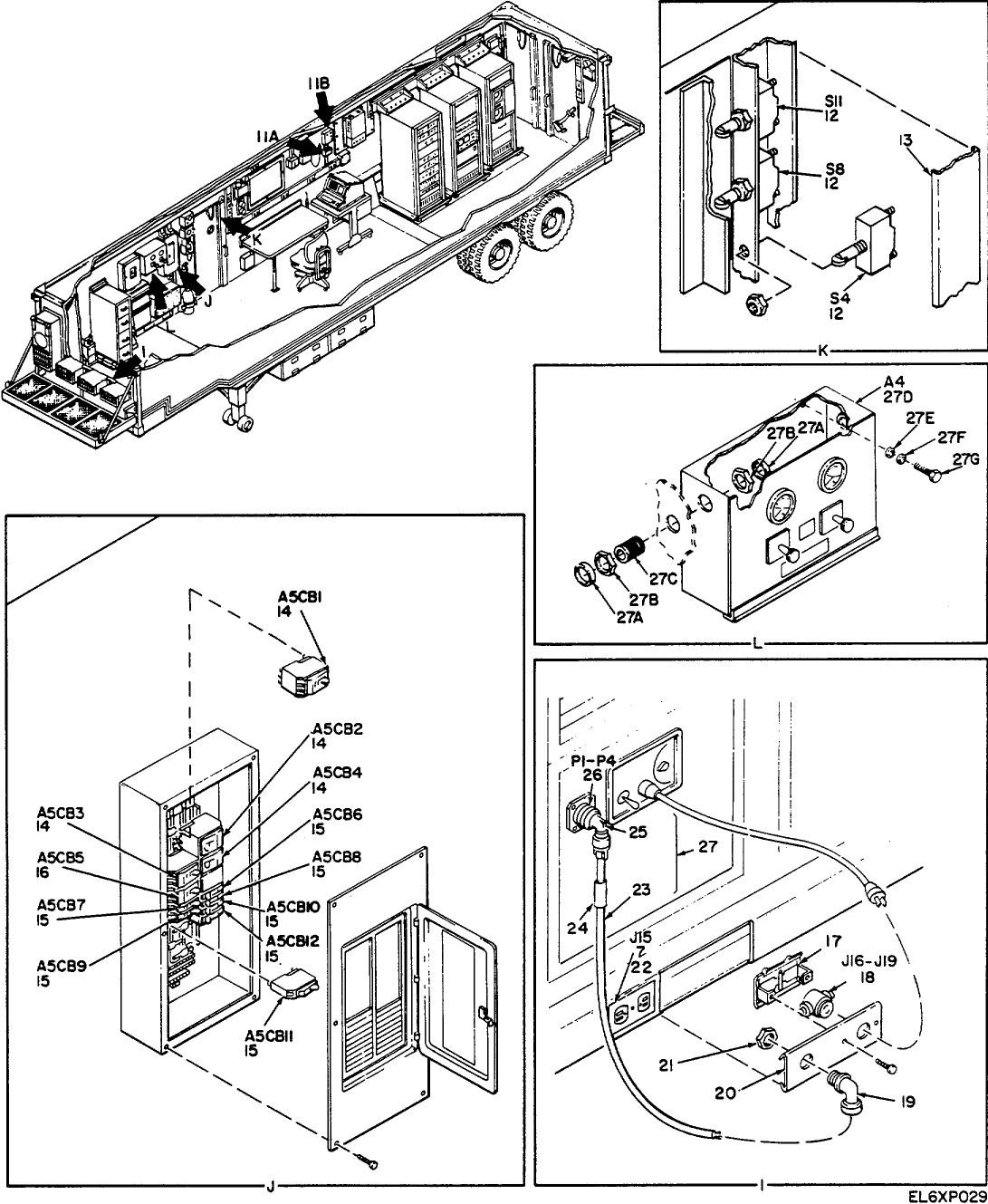

Figure 3. Electrical Installation (Sheet 2 of 7).

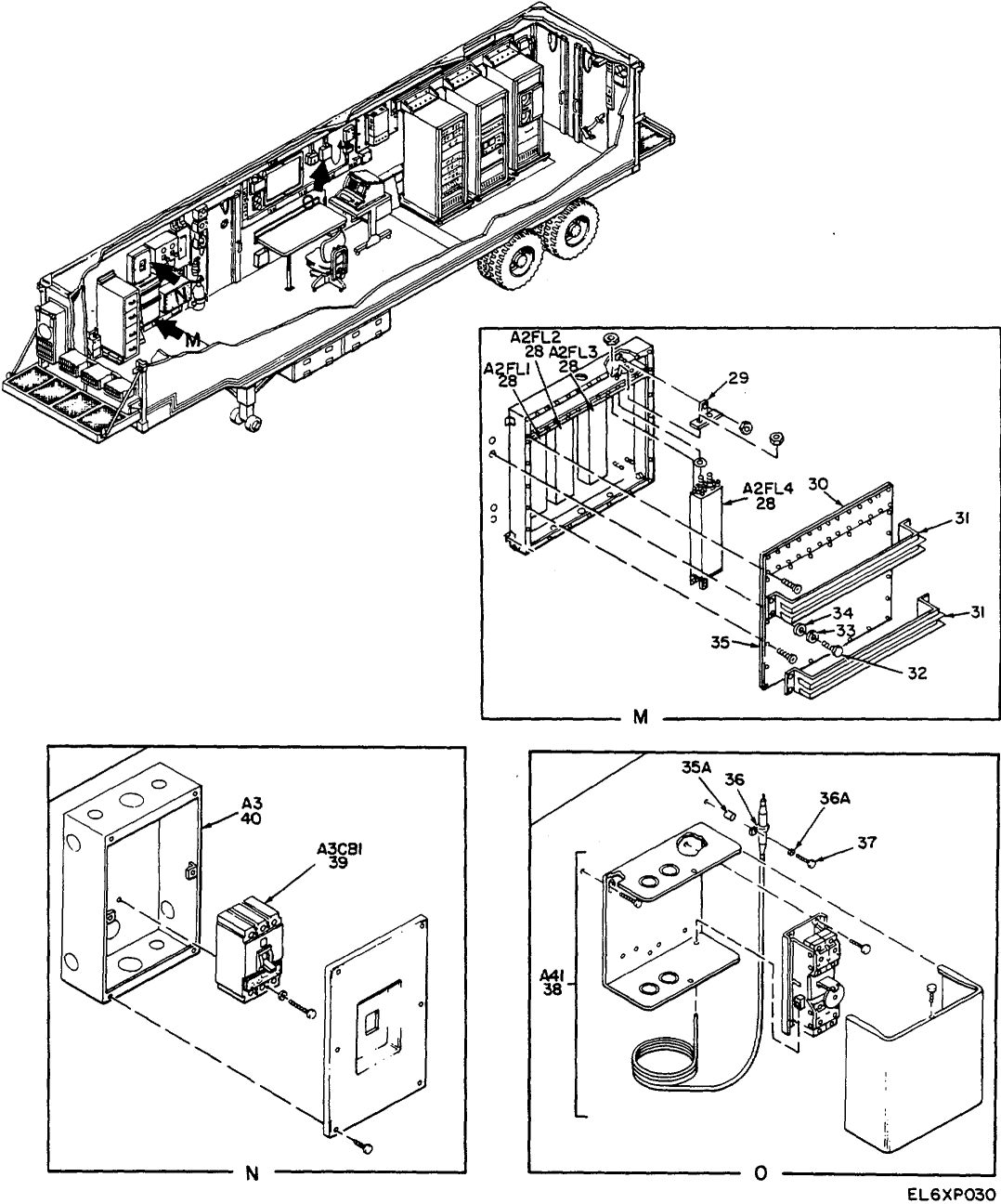
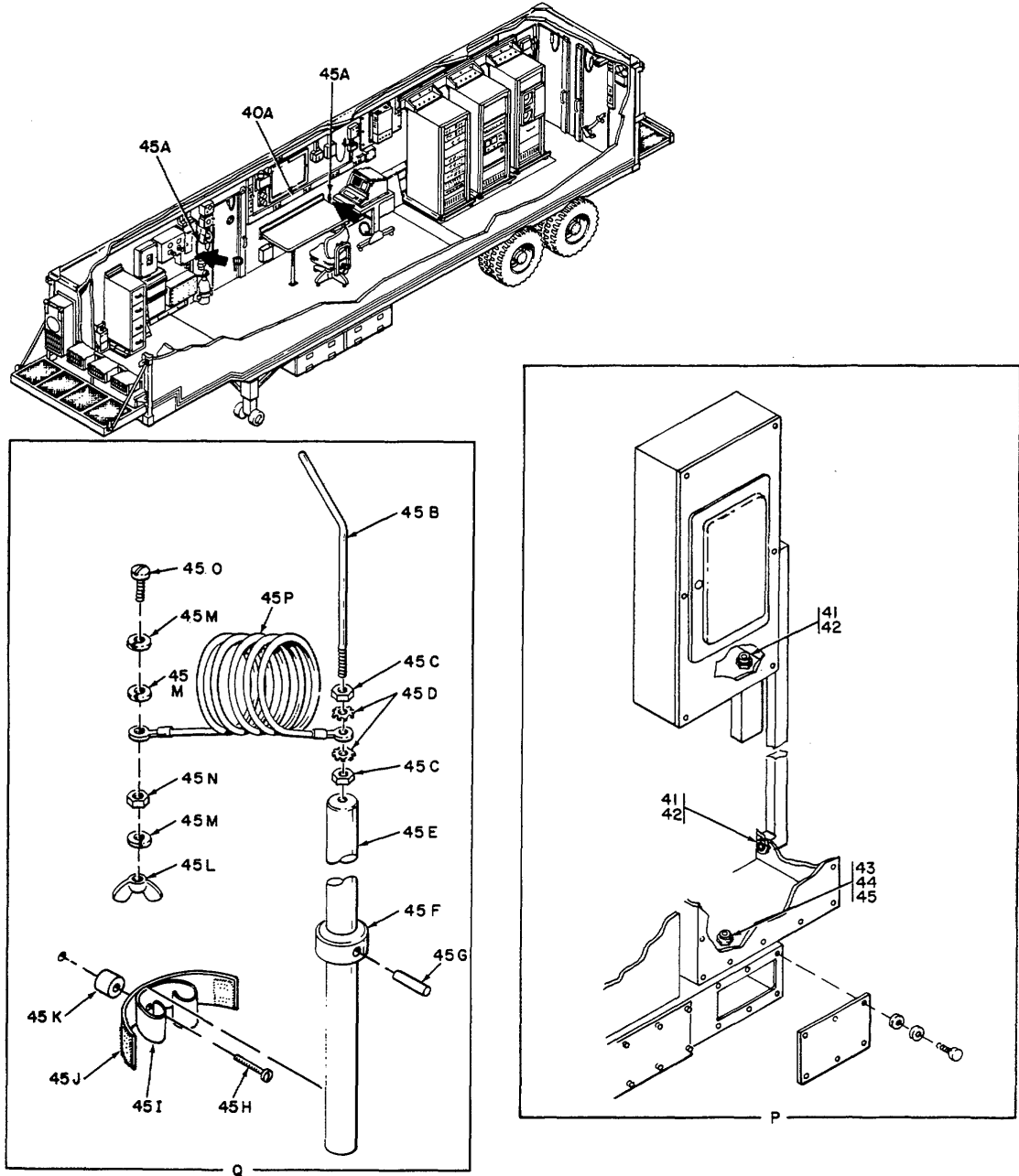
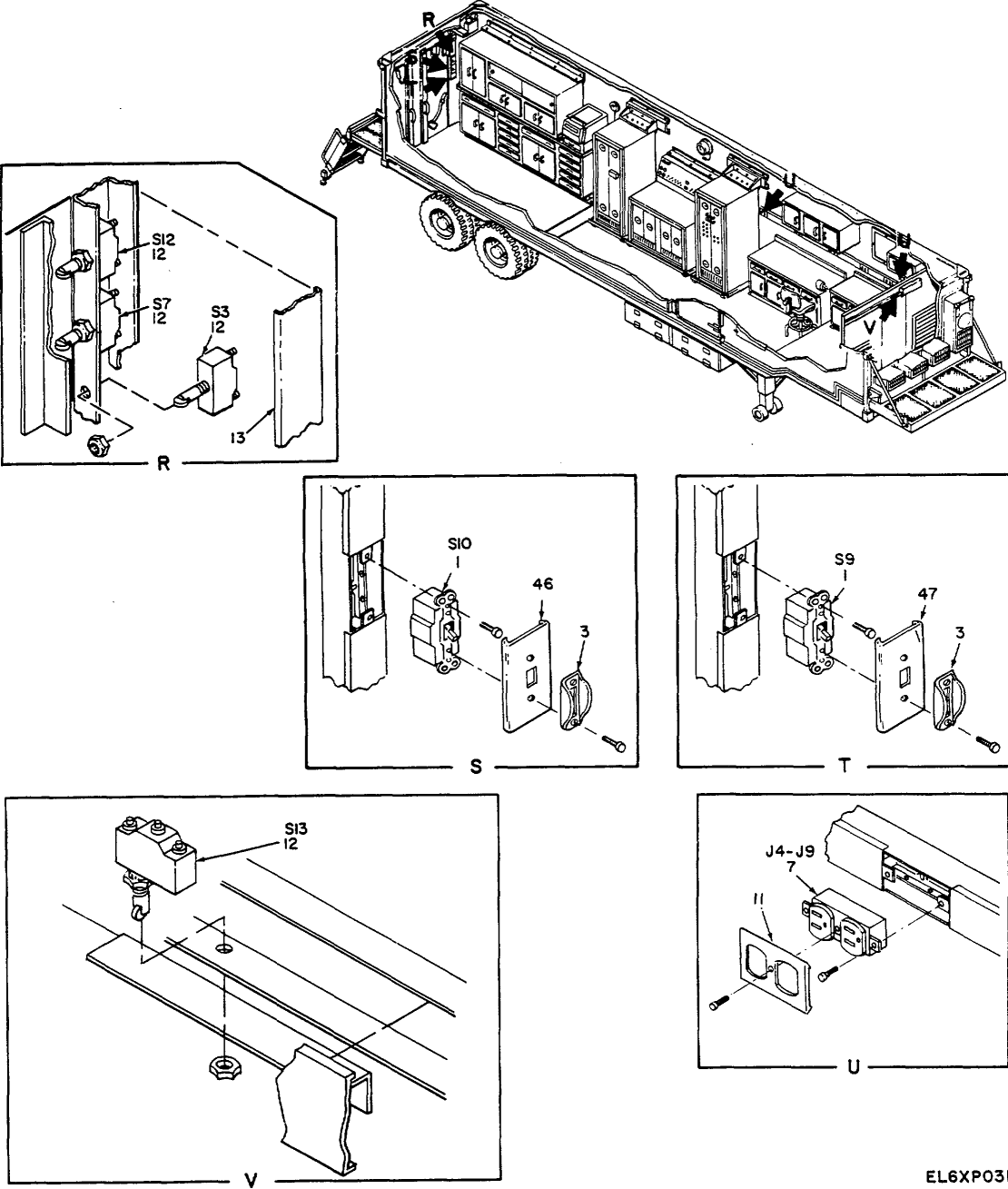

Figure 3. Electrical Installation (Sheet 3 of 7).



EL6XP027

Figure 3. Electrical Installation (Sheet 4 of 7).



EL6XP031

Figure 3. Electrical Installation (Sheet 5 of 7).

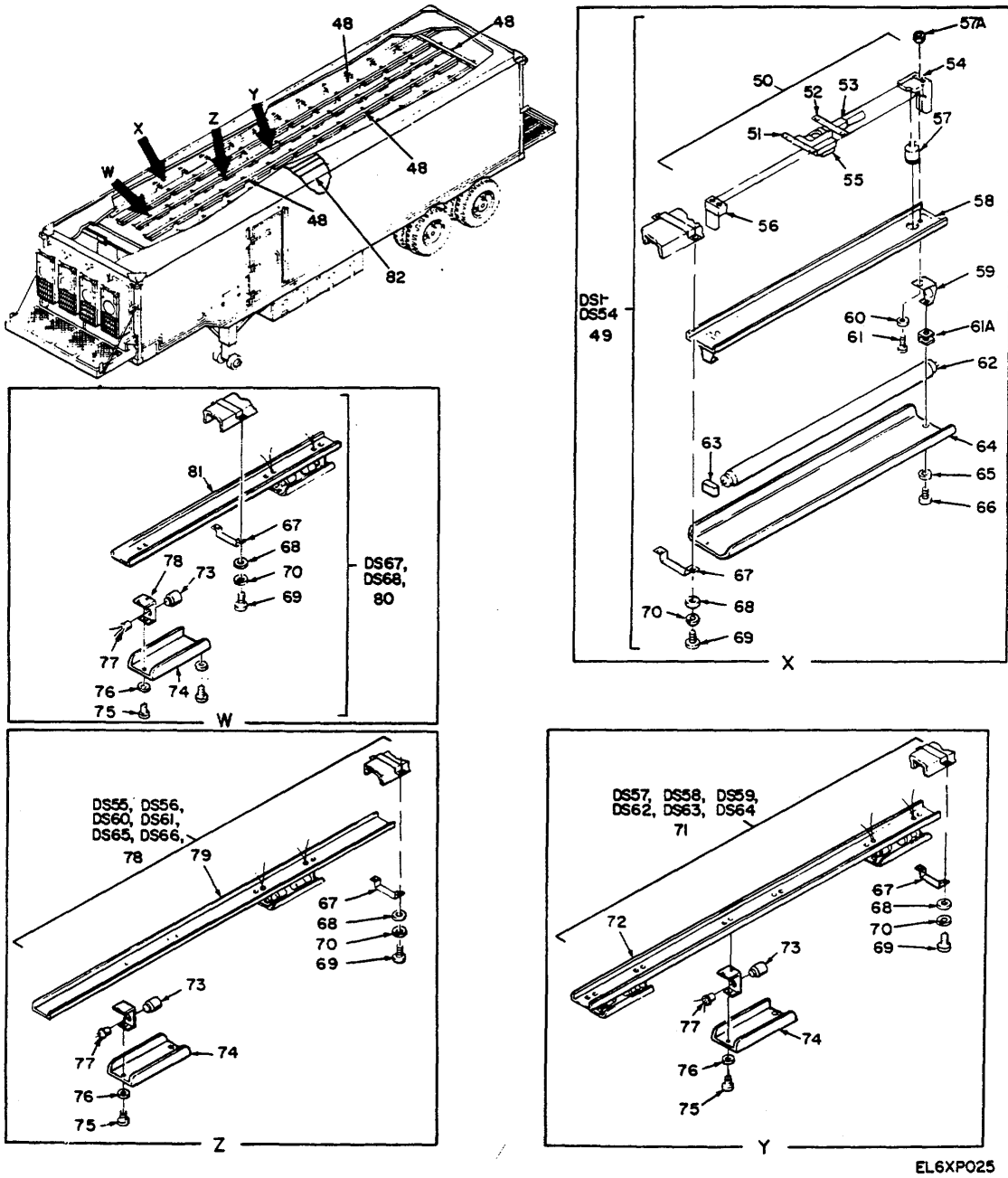

Figure 3. Electrical Installation (Sheet 6 of 7).

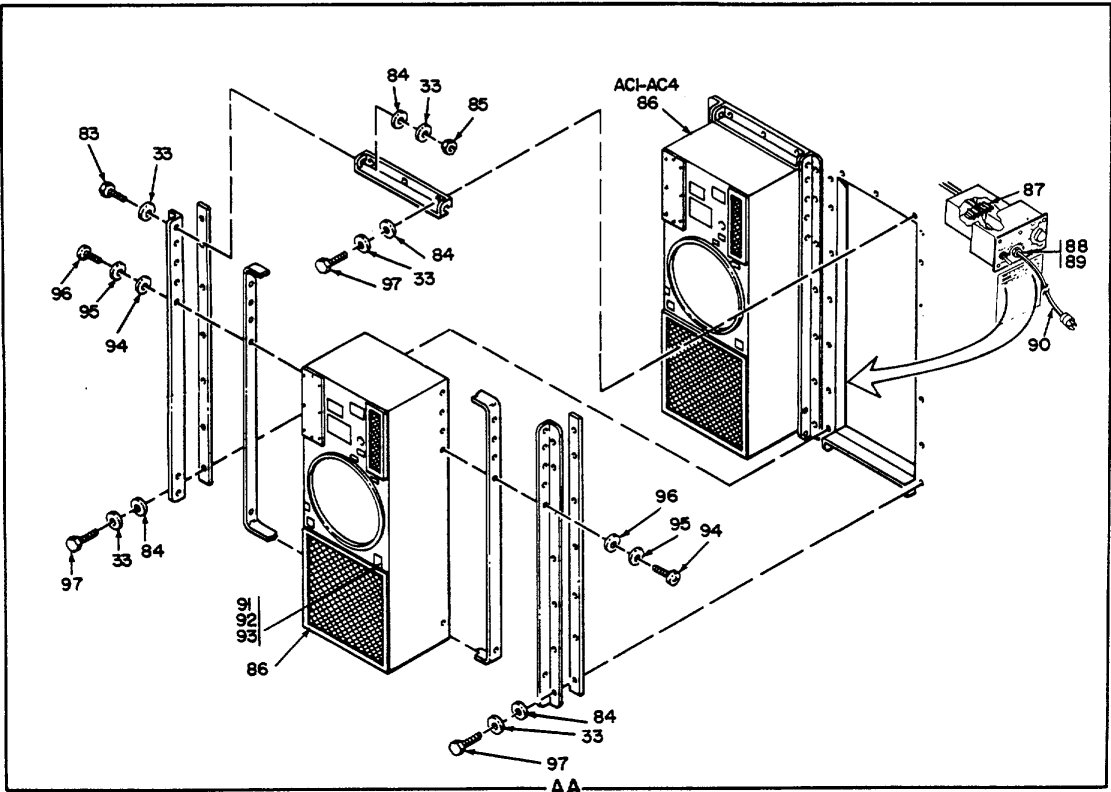
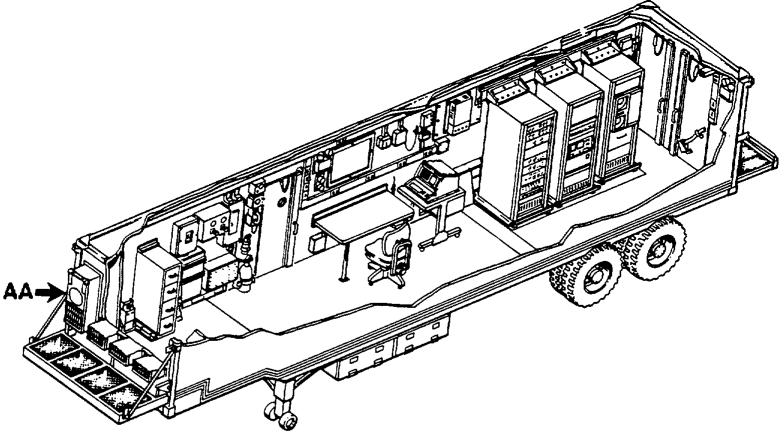

Figure 3. Electrical Installation (Sheet 7 of 7).

SECTION II

TM 11-5410-216-24P

(1) ILLUSTRATION		(2)	(3)	(4)	(5)	(6) DESCRIPTION	(7)	(8)
(a) FIG NO.	(b) ITEM NO.	SMR CODE	NATIONAL STOCK NUMBER	FSCM	PART NUMBER	USABLE ON CODE	U/M	QTY INC IN UNIT
						GROUP 0101 ELECTRICAL INSTALLATION		
3	1	PAGZZ		81348	MS896/12-3A	SWITCH	EA	6
3	2	XDFZZ		56996	84008173-001	COVER, SWITCH.....	EA	1
3	3	XDFZZ		56996	84008471	GUARD, SWITCH.....	EA	6
3	4	XDFZZ		56996	84008173-002	COVER, SWITCH.....	EA	1
3	5	XDFZZ		56996	84008173-004	COVER., SWITCH.....	EA	1
3	6	XDFZZ		56996	84008173-005	COVER., SWITCH.....	EA	1
3	7	PAFZZ	5935-01-111-5568	81348	WC596712-2	CONNECTOR, RECEPTAC.....	EA	1
3	8	XDFZZ		56996	8408576-001	COVER, RECP, DUPLEX.....	EA	1
3	9	XDFZZ		56996	84008405	COVER, RECP, DUPLEX.....	EA	1
3	10	XDFZZ		56996	84008575	COVER, RECP, DUPLEX.....	EA	10
3	11	XDFZZ		56996	84008577-002	COVER, RECP, DUPLEX.....	EA	1
3	11A	PAOZZ	5930-00-636-2726	27319	T6051A1016	SWITCHTHERMOSTATIC	EA	1
3	11B	XOOFF		56996	84008718	ALAR BOX ASSY	EA	1
3	12	PAOZZ	5930-00-683-2703	96306	BZ-2RQ18A2	SWITCH, SENSITIVE	EA	7
3	13	XDOZZ		56996	34008170	COVER, RACEWAY	EA	10
3	14	PADZZ	5925-01-092-9573	81348	WC375/02-004	CIRCUIT BREAKER	EA	4
3	15	PADZZ	5925-01-042-0109	81348	WC375/01-002	CIRCUIT BREAKER	EA	6
3	16	PADZZ	5925-01-042-5072	81348	WC375/03-005	CIRCUIT BREAKER	EA	1
3	17	XDFZZ		56996	84008178	BRACKET.....	EA	4
3	18	PAFZZ		81348	NC596/19-1	CONNECTOR RECEPACL.....	EA	4
3	19	XDFZZ		56996	84008474	CONNECTOR,SIN REL.....	EA	4
3	20	XDFZZ		56996	84008172	COVER, RACEWAY	EA	4
3	21	XOFZZ		80063	SC-C-681071-3	LOCKTNUIT	EA	4
3	22	XDOZZ		56996	84008425	COVER, RECEPTACLE	EA	1
3	23	XBFZZ		81349	C0-0440F-0665	CABLE	EA	1
3	24	XBFZZ		80063	SC-C-681320-9	BAND, IDENT	EA	1
3	25	PAFZZ		96906	MS3056-12A	ADAPTER.....	EA	1
3	26	PAFZZ		96906	MS3108A22-225	CONNECTOR.....	EA	1
3	27	PAFFF		56996	84008378	CABLE ASSEMNLNLY POWE.....	EA	4
3	27A	XOFZZ		56996	84008412	BUSHING	EA	4
3	27B	XOFZZ		80063	SC-C-681078-6	LOCKNUT.....	EA	3
3	27C	XDFZZ		56996	84008117	NIPPLE.....	EA	2
3	27D	XOFFF		56996	84008038	METER BOX ASSY	EA	1
3	27E	PAFZZ	5310-00-582-5677	96906	MS15795-810	WASHER, FLAT	EA	16
3	27F	PAFZZ	5310-00-933-8121	96906	MS35338-139	WASHER, LOCK	EA	16

SECTION II

TM 11-5410-216-24P

(1) ILLUSTRATION		(2)	(3)	(4)	(5)	(6)	(7)	(8)
(a) FIG NO.	(b) ITEM NO.	SMR CODE	NATIONAL STOCK NUMBER	FSCM	PART NUMBER	DESCRIPTION USABLE ON CODE	U/M	QTY INC IN UNIT
3	27G	PAFZZ	5305-00-207-2297	96906	NS35307-312	SCREW, CAP, HEXAGON H.....	EA	8
3	27H	XDFZZ		56996	84008036	PWR ENT BOX INS.....	EA	1
3	28	PAFZZ	5915-01-124-7037	02777	F-3569	FILTER, RF.....	EA	4
3	29	PAFZZ		02777	4.900.0069-4	BUS CONDUCTOR.....	EA	4
3	30	PAFZZ		56996	84008120	GASKET.....	EA	1
3	31	XDFZZ		56996	84008355	STRAP ASSY.....	EA	2
3	32	PAFZZ	5305-00-988-1724	96906	MS35206-280	SCREW, MACHINE.....	EA	8
3	33	PAFZZ	5310-00-974-6623	96906	MS35338-140	WASHER, LOCK.....	EA	140
3	34	PAFZZ	5310-00-081-4219	96906	MS27183-12	WASHER, LOCK.....	EA	12
3	35	XDFZZ		56996	B4008119	GASKET.....	EA	1
3	35A	PAOZZ		56996	B4008677	STANDOFF.....	EA	2
3	36	PAFZZ	5340-00-187-6023	96906	MS21122-6	CLAMP, LOOP.....	EA	2
3	37	PAFZZ	5305-00-432-4206	96906	MS51861-50	SCREW, TAPPING, THREA.....	EA	1
3	38	PAOZZ		56996	B4008359	THERMOSTAT.....	EA	1
3	39	PAOZZ	5925-01-122-4739	81922	KAL36100	CIRCUIT BREAKER.....	EA	1
3	40	XDOZZ		56996	84008390	ENCLOSURE.....	EA	1
3	40A	XC		56996	84008032	RACEAY INSTALL.....	EA	1
3	41	XDFZZ		80063	SC-C-681077-1	CHASE NIPPLE.....	EA	3
3	42	XDFZZ		80063	SC-C-681078-2	LOCKNUT.....	EA	3
3	43	XDFZZ		80063	SC-C-681077-6	CHASE NIPPLE.....	EA	1
3	44	XDFZZ		56996	B4008107	SPACER.....	EA	1
3	45	XDFZZ		80063	SC-C-681078-7	LOCKNUT.....	EA	9
3	45A	XDFZZ		56996	84008734	PROBE, SHORTING ASSY.....	EA	2
3	45B	PAFZZ		56996	84008735	ROD, PROBE.....	EA	1
3	45C	PAFZZ	5310-00-855-1102	96906	MS35649-2255	NUT, PLAIN, HEXAGN.....	EA	2
3	45D	PAFZZ	5310-00-022-8834	96906	MS35333-108	WASHER, LOCK.....	EA	2
3	45E	XDFZZ		56996	84008736	HANDLE, PROBE.....	EA	1
3	45F	XDFZZ		56996	84008737	COLLAR, PROBE.....	EA	1
3	45G	XDFZZ	5315-00-844-3965	96906	MS16562-48	PIN, SPRING.....	EA	1
3	45H	PAFZZ		96906	MS35214-61	SCREW, MACHINE.....	EA	2
3	45I	PAFZZ		56996	84008758	SPRING CLIP HOLDER.....	EA	2
3	45J	XDFZZ		56996	84008776	STRAP, PROBE.....	EA	4
3	45K	PAFZZ		56996	84008677-002	STANDOFF.....	EA	2
3	45L	PAFZZ	5310-00-131-2247	96906	MS35426-26	NUT, PLAIN, WING.....	EA	1
3	45M	PAFZZ	5310-00-942-5110	96906	MS35335-88	WASHERLOCK.....	EA	3
3	45N	PAFZZ	5310-00-934-9766	96906	MS35650-305	NUT, PLAIN, HEXAGON.....	EA	1
3	45O	PAFZZ	5305-00-954-8152	96906	MS35215-59	SCREW, MACHINE.....	EA	1
3	45P	PAFZZ		56996	84008738	WIRE ASSY.....	EA	1

(1) ILLUSTRATION		(2)	(3)	(4)	(5)	(6)	(7)	(8)
(a) FIG NO.	(b) ITEM NO.	SMR CODE	NATIONAL STOCK NUMBER	FSCM	PART NUMBER	DESCRIPTION USABLE ON CODE	U/M	QTY INC IN UNIT
3	46	XDFZZ		56996	84008173-003	COVER, SWITCH.....	EA	1
3	47	XDFZZ		56996	84008173-008	COVER, SWITCH.....	EA	1
3	48	XDDZZ		56996	84008169	COVER, RACEWAY.....	EA	10
3	49	XDDOO		56996	84008100	FIXTURE ASS.....	EA	20
3	50	PADDOO		56996	84008347	SUB ASSEMBLY, FIXTU.....	EA	1
3	51	XDDZZ		80063	SC-C-539558	COVER, BALLAST.....	EA	2
3	52	XDDZZ	6250-00-408-2639	80063	SC-B-539568	SUPPORT BALLAST.....	EA	2
3	53	PADZZ	5915-01-073-6128	80063	SC-C-681186	FILTER, RADIO FREQU.....	EA	1
3	54	PADZZ	6210-01-106-6116	80063	SC-C-681183	MOUNT, LAMP.....	EA	1
3	55	PADZZ	6250-00-804-3449	80063	SC-C-681185	BALLAST, LMAP.....	EA	1
3	56	PADZZ	6210-01-110-2240	80063	SC-C-681184	MOUNT, LAMP.....	EA	1
3	57	PADZZ		80063	SC-C-539504	LAMP, STARTER.....	EA	1
3	57A	PADZZ	5310-00-680-6627	96906	MS25082-1	NUT, PLAIN HEXGON.....	EA	2
3	58	XDDZZ		56996	84008240	COVER.....	EA	1
3	59	XDDZZ	6250-00-449-7859	80063	SC-C-681035	COVER, LAMP.....	EA	2
3	60	PADZZ	5310-00-045-3299	96906	MS35338-4	WASHER, LOCK.....	EA	2
3	61	PADZZ		96906	M535208-329	SCREW.....	EA	2
3	62	PADZZ	6240-00-152-2996	80063	SC-C-539495	LAMP, FLUORESCENT.....	EA	1
3	63	XDOZZ	6210-00-757-9694	80063	SC-C-539498	7LOCK, LAMP FLUORES.....	EA	2
3	64	XDOZZ	6210-00-921-6682	80063	SC-C-539466	WINDOW, LIGHTING FIX.....	EA	2
3	65	PADZZ	5310-00-809-8544	96906	MS527183-7	WASHER, FLAT.....	EA	2
3	66	PADZZ	5305-00-984-6193	96906	MS35206-245	SCREW, MACHINE.....	EA	2
3	67	XOFZZ		56996	84008174-001	CLIP, COVER.....	EA	50
3	66	XOFZZ		96906	MS21783-5	WASHER, FLAT.....	EA	100
3	69	PAFZZ	5305-00-984-4988	96906	MS35206-228	SCREW, MACH.....	EA	100
3	70	PAFZZ	5310-00-045-4007	96906	MS35338-41	WASHER, LOCK.....	EA	100
3	71	XDDOO		56996	84008161	FIXTURE ASSY.....	EA	2
3	72	XDDZZ		56996	84008241	COVER.....	EA	1
3	73	PADZZ		08806	25T8DC	LAMP, INCADESCENT.....	EA	4
3	74	XDDZZ	6210-00-451-8350	80063	SC-C-539466-1	WINDOW, LIGHTING FIX.....	EA	2
3	75	PADZZ	5305-00-984-6193	96906	MS35206-245	SCREW, MACHINE.....	EA	2
3	76	PADZZ	5310-00-809-8544	96906	MS27183-7	WASER, FLAT.....	EA	2
3	77	PADZZ	6250-00-995-9071	80063	SC-C-681207	LAMPHOLDER.....	EA	4
3	78	XDOOO		56996	84008159	FIXTURE ASSY.....	EA	3
3	79	XDDZZ		56996	84008239	COVER.....	EA	1
3	80	XDDOO		56996	84008162	FIXTURE ASSY.....	EA	1
3	81	XDFZZ		56996	84008349	COVER.....	EA	1
3	82	XC		56996	54008034	PNL AND DCT INS.....	EA	1
3	83	PAFZZ	5306-00-637-9675	96906	MS35307-332	BOLT, MACHINE.....	EA	16
3	84	PAFZZ	5310-00-625-5756	96906	MS15795-812	WASHER FLAT.....	EA	8

SECTION II

TM 11-5410-216-24P

(1) ILLUSTRATION		(2)	(3)	(4)	(5)	(6)	(7)	(8)
(a) FIG NO.	(b) ITEM NO.	SMR CODE	NATIONAL STOCK NUMBER	FSCM	PART NUMBER	DESCRIPTION USABLE ON CODE	U/M	QTY INC IN UNIT
3	85	PAFZZ	5310-00-767-0445	96906	MSS1971-2	NUT, PLAIN HEXAGON	EA	14
3	86	XDFDD		56996	B4008506	AIR COND, MOD	EA	4
3	87	XOFZZ	5940-00-983-6122	81349	39TB-2-	TERMINAL BOARD	EA	1
3	88	XOFZZ		56996	84008280-001	STRAIN RELIEF, CONN	EA	1
3	89	XDFZZ		80063	SC-C-681078-2	LOCKNUT	EA	1
3	90	PAFZZ		56996	B4008321-003	CABLE A SSEBLY	EA	1
3	91	XDFZZ		56996	B4004s81	GASKET	EA	1
3	92	XDFZZ		80063	SC-C-539759-1	RIVET, DOME PO	EA	4
3	93	XDFZZ		56996	B4008480	COVER	EA	1
3	94	PAFZZ	5310-00-883-9384	96904	MS15795-842	WASHER, FLAT	EA	40
3	95	PAFZZ	5310-00-933-8120	96906	M535338-138	WASHER LOCK	EA	40
3	96	PAFZZ	5305-00-059-3661	96906	MS51958-652	SCREW, MACHINE	EA	40
3	97	PAFZZ	5306-00-637-9674	9690	MS35307-336	BOLT, MACHINE	EA	80

26/(27 BLANK)

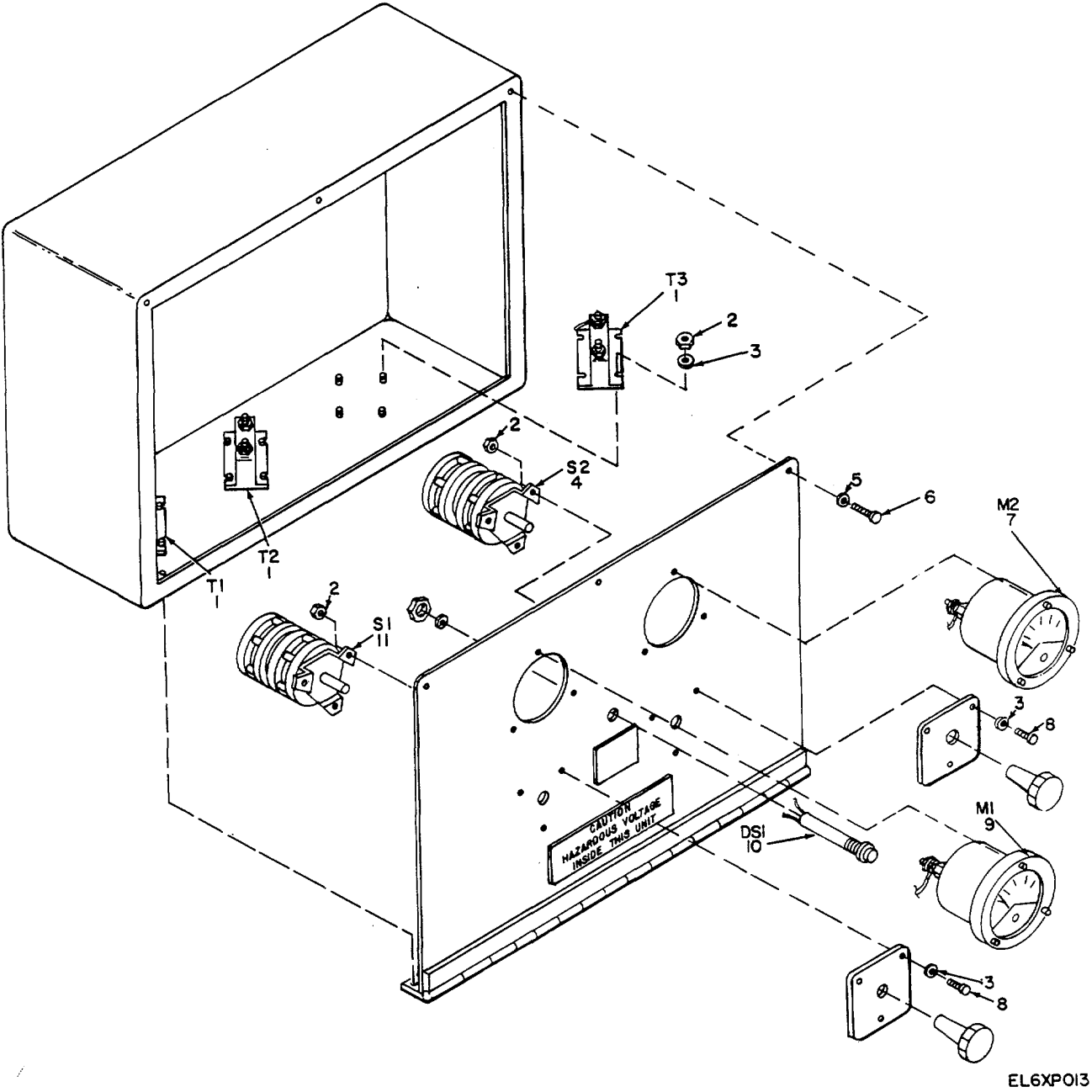
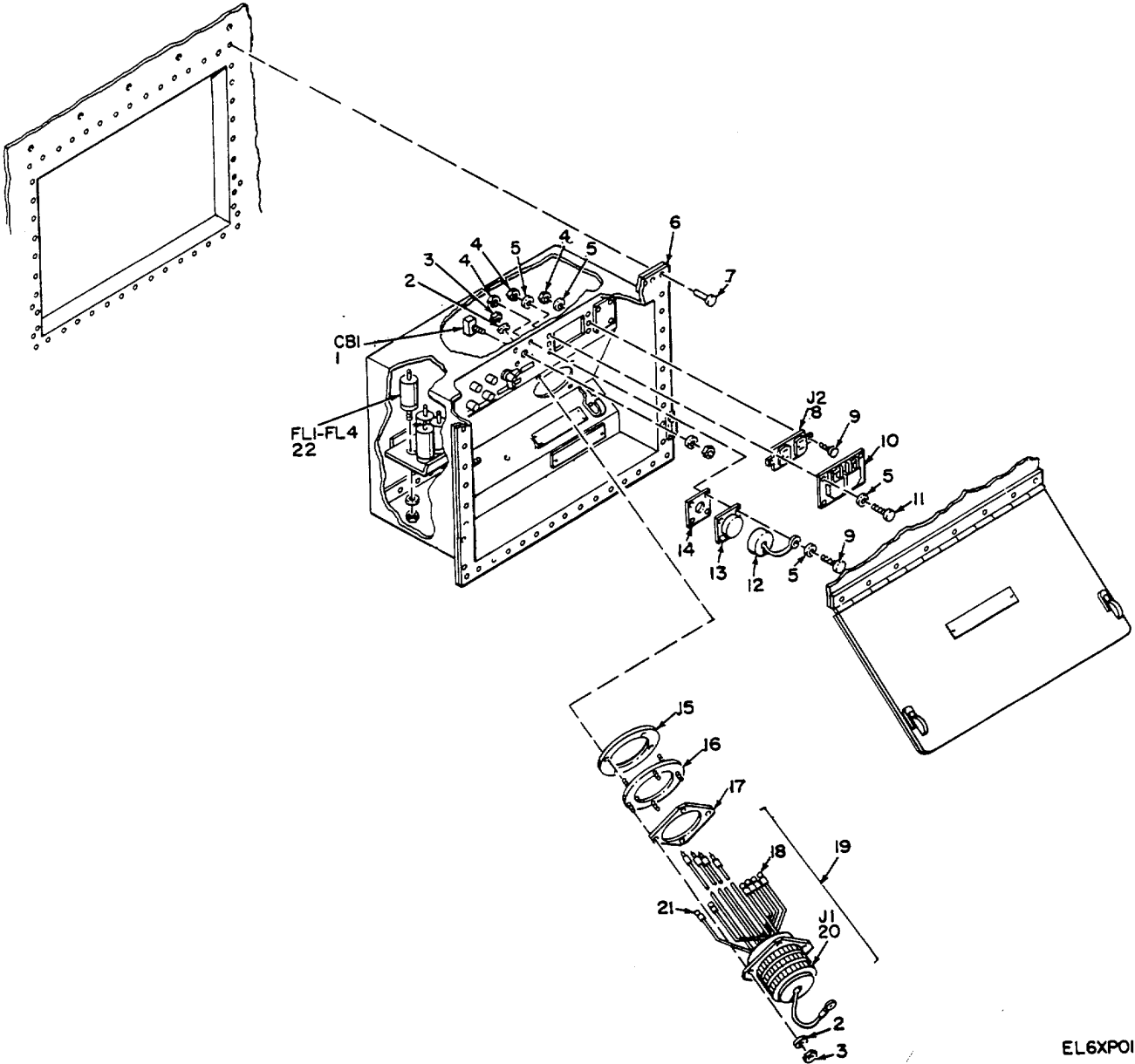

Figure 4. Meter Box Assembly, 3-Phase, 120/208 Vac.

SECTION II

TM 11-5410-216-24P

(1) ILLUSTRATION		(2)	(3)	(4)	(5)	(6)	(7)	(8)
(a) FIG NO.	(b) ITEM NO.	SMR CODE	NATIONAL STOCK NUMBER	FSCM	PART NUMBER	DESCRIPTION USABLE ON CODE	U/M	QTY INC IN UNIT
						GROUP 01010102 METER BOX ASSEMBLY		
4	1	PAFZZ		53498	802-43-U-RLLF	CURRENT TRANSFORME.....	EA	3
4	2	PAFZZ	5310-00-811-3494	96906	MS21044N0B	NUT, SELF-LOCKING, HE	EA	18
4	3	PAFZZ	5310-00-809-8544	96906	MS27183-7	WASHER, FLAT	EA	18
4	4	PAFZZ	5930-00-570-5477	82121	2410H	SWITCH, ROTARY.....	EA	1
4	5	PAFZZ	5310-00-014-5850	96906	MS27183-42	WASHER, FLAT	EA	3
4	6	PAFZZ	5305-00-989-6265	96906	MS35207-262	SCREW, MACHINE.....	EA	3
4	7	PAFZZ		81349	MR36W200ACAAR	AMMETER.....	EA	1
4	8	PAFZZ	5305-00-984-6193	96906	MS35206-245	SCREW, MACH.....	EA	6
4	9	PAFZZ		81349	MR36W300ACWR	VOLT METER.....	EA	1
4	10	PAFZZ	6210-01-073-5583	52797	2A-5C5	LIGHT, INDICATOR.....	EA	1
4	11	PAFZZ	5930-00-148-8929	82121	2405H	SWITCH, ROTARY.....	EA	1
					29			



EL6XPO14

Figure 5. Power Entrance Box.

SECTION II

TM 11-5410-216-24P

(1) ILLUSTRATION		(2)	(3)	(4)	(5)	(6) DESCRIPTION	(7)	(8)
(a) FIG NO.	(b) ITEM NO.	SMR CODE	NATIONAL STOCK NUMBER	FSCM	PART NUMBER	USABLE ON CODE	U/M	QTY INC IN UNIT
						GROUP 01010103 POWER ENTRANCE BOX		
5	1	PAFZZ	5925-00-686-3297	96906	MS25244-5	CIRCUIT BREAKER	EA	1
5	2	PAFZZ	5310-00-809-3078	96906	MS27183-11	WASHER, FLAT	EA	8
5	3	PAFZZ	5310-00-088-1251	96906	MS51922-1	NUT, SELF-LOCKING, HE	EA	8
5	4	PAFZZ	5310-00-807-1465	96906	MS21042-06	NUT, SELF-LOCKING, EX.....	EA	16
5	1	PAFZZ	5310-00-983-8483	96906	MS27183-5	WASHER, FLAT	EA	16
5	6	XDFFF		56996	B4008260	BOX ASSY PWR EN	EA	1
5	7	PAFZZ	5320-00-490-5523	81349	M24243/7-A606H	RIVET, BLIND.....	EA	42
5	8	PAFZZ	5935-01-017-3290	81348	WC596/12-3	CONNECTOR, RECEPTACL.....	EA	1
5	9	PAFZZ	5305-00-889-3001	96906	MS35206-231	SCREW, MACHINE	EA	4
5	10	XDFZZ		80063	SC-C-681092	COVER, WEATHERPF.....	EA	1
5	11	PAFZZ	5305-00-984-4992	96906	MS35206-232	SCREW MACHINE	EA	4
5	12	XOFZZ	5935-00-137-4879	96906	MS25043-28D	COVER, ELECTRICAL Cu.....	EA	1
5	13	PAFZZ		74545	10-37093-323	CONNECTOR.....	EA	1
5	14	PAFZZ		80063	SC-C-681422	GASKET, CONNECTOR.	EA	1
5	15	PAFZZ		56996	8400847	GASKET	EA	1
5	16	XDFZZ		56996	84008270	PLATE, CONN ADAPT	EA	1
5	17	PAFZZ		56996	8400841178	GASKET	EA	1
5	18	PAFZZ	5940-00-114-1305	96906	525036-116	TER5INAL,LUG	EA	4
5	19	PAFFF	5995-01-134-6634	56996	84008273	CABLE ASSEMBLY, POWE	EA	1
5	20	PAFZZ		96906	MS90558C44412P	CONNECTOR, RECEPTACL.....	EA	1
5	21	PAFZZ	5940-00-143-4775	96906	MS25036-156	TERII1NALLUG	EA	2
5	22	PAFZZ		56996	84008454	FILTER RADIO, FREQ	EA	4
31								

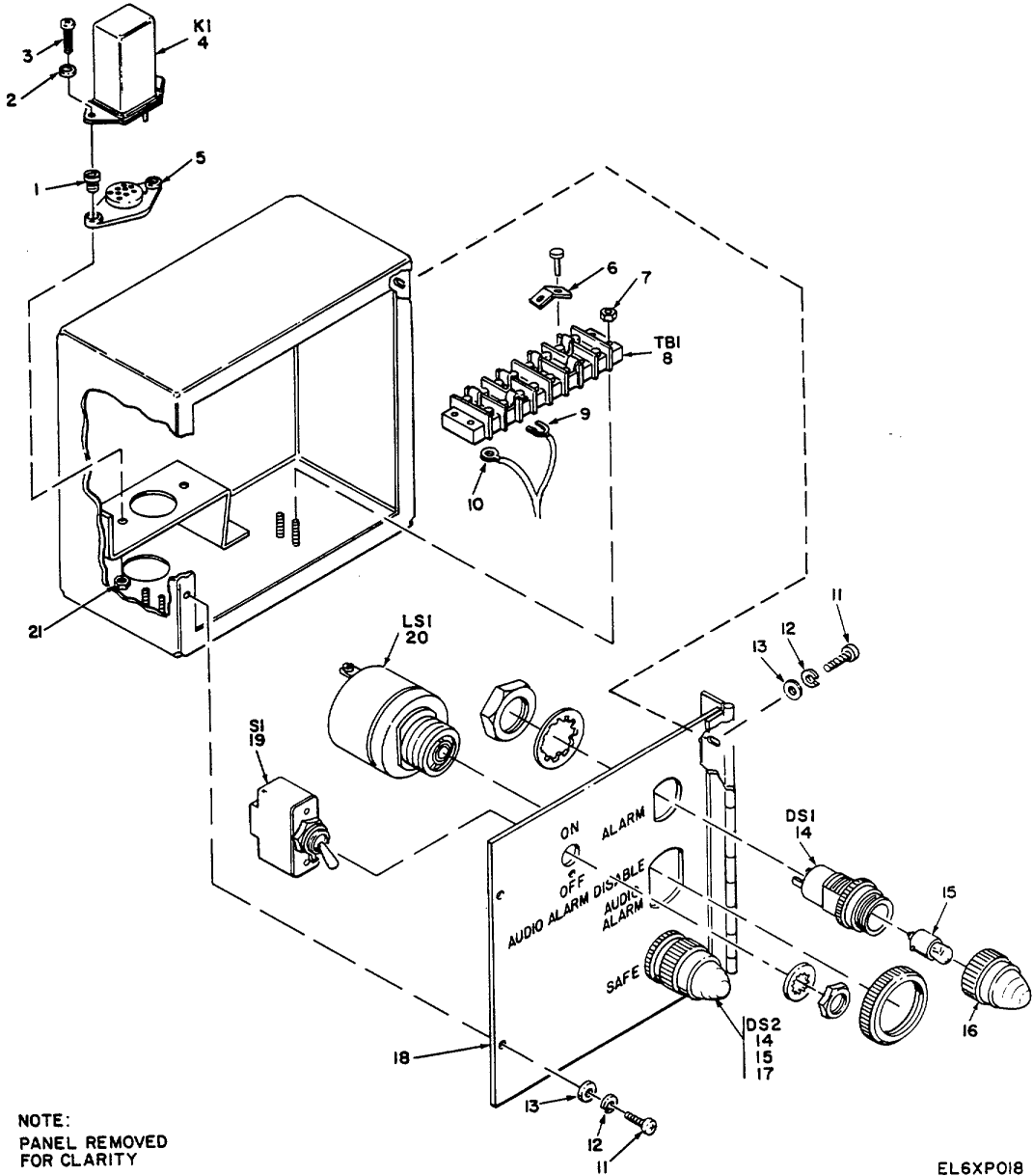
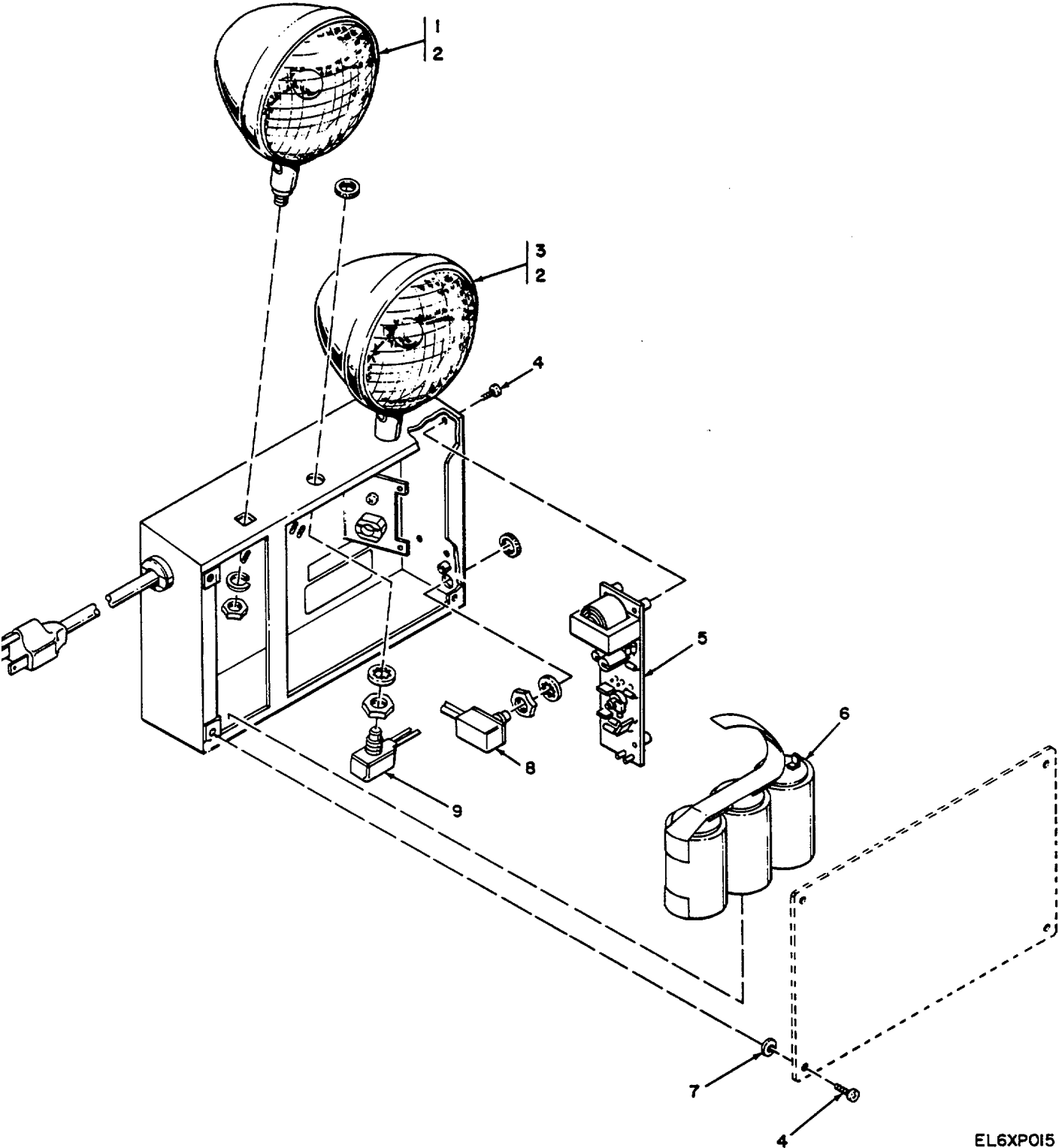

Figure 6. Alarm Box Assembly.

SECTION II

TM 11-5410-216-24P

(1) ILLUSTRATION		(2)	(3)	(4)	(5)	(6) DESCRIPTION	(7)	(8)
(a) FIG NO.	(b) ITEM NO.	SMR CODE	NATIONAL STOCK NUMBER	FSCM	PART NUMBER	USABLE ON CODE	U/M	QTY INC IN UNIT
						GROUP 010108 ALARM BOX ASSEMBLY		
6	1	PAOZZ	5305-00-910-5363	96906	MS25332-1	SCREW, MACHINE	EA	2
6	2	PAOZZ	5310-00-836-2458	88044	AN935-5	WASHER, LOCK	EA	2
6	3	PAOZZ	5305-00-842-0241	80205	NAS600-6	SCREW, MACHINE	EA	2
6	4	PAOZZ		35344	9227-55	RELAY ELECTROMAGNET/T	EA	1
6	5	XDOZZ	5935-00-925-6396	96906	MS25324-4	SOCKET, PLUG-IN ELEC	EA	1
6	6	XAOZZ		56996	84008725	PLATE, SCHEMATIC ALA.....	EA	1
6	7	PAOZZ	5310-00-146-7102	96906	MS25082-C1	NUT, PLAIN, HEXAGON.	EA	4
6	8	XDOZZ	5940-00-983-6086	81349	38T1-8	TERMINAL BOARD	EA	1
6	9	XDOZZ	5940-00-703-9241	96906	MS17143-5	TERMINAL, LUG	EA	10
6	10	XDOZZ	5940-00-143-4774	96906	MS25036-153	TERMINAL, LUG	EA	2
6	11	PAOZZ		96906	MS51957-28	SCREW, MACHINE	EA	6
6	12	PAOZZ	5310-00-929-6395	96906	MS35338-136	WASHER, LOCK	EA	6
6	13	PAOZZ	5310-00-880-5976	96906	MS15795-806	WASHER, FLAT	EA	6
6	14	PAOZZ	6210-00-753-2289	81349	LH80-1	LIGHT INDICATOR.....	EA	1
6	15	PAOZZ		56996	84008722	LAMP, INCAND	EA	2
6	16	PAOZZ		81349	LC22RD3	LENS, LIGHT	EA	1
6	17	PAOZZ		81349	LC22GD3	LENS, LIGHT	EA	1
6	18	XAOZZ		56996	84008721	COVER, ASSY	EA	1
6	19	PAOZZ	5930-00-683-1628	96906	MS24523-22	SWITCH, TOGGLE.....	EA	1
6	20	PAOZZ	6350-01-044-2588	06124	SC11OM	BUZZER	EA	1
6	21	PAOZZ	5310-00-877-5797	96906	MS20365-1032A	NUT, SELF-LOCKING	EA	2



EL6XPO15

Figure 7. Emergency Lighting.

SECTION II

TM 11-5410-216-24P

(1) ILLUSTRATION		(2)	(3)	(4)	(5)	(6)	(7)	(8)
(a) FIG NO.	(b) ITEM NO.	SMR CODE	NATIONAL STOCK NUMBER	FSCM	PART NUMBER	DESCRIPTION USABLE ON CODE	U/M	QTY INC IN UNIT
						GROUP 0103 EMERGENCY LIGHT		
7	1	PAOZZ		80538	610689-1	LAMPHEAD ASSEMBLY	EA	2
7	2	PAOZZ	6240-01-072-2278	08806	7613	LAMP, INCANDESCENT	EA	2
7	3	PAOZZ		80538	610689-3	LAMPHEAD ASSEMBLY	EA	2
7	4	PAOZZ		33525	726016	SCREW MACHINE	EA	8
1	5	PAOZZ		80538	610692-1	PRINTED CIRCUIT	EA	1
7	6	PAOZZ	6135-01-134-6633	80538	610518	BATTERY ASSEMBLY	EA	1
7	7	PAOZZ		33525	719736	WASHER FIBRE	EA	4
7	a	PAOZZ		80536	610815	SWITCH	EA	1
7	9	PAOZZ		80538	610814	SWITCH	EA	1
					35			

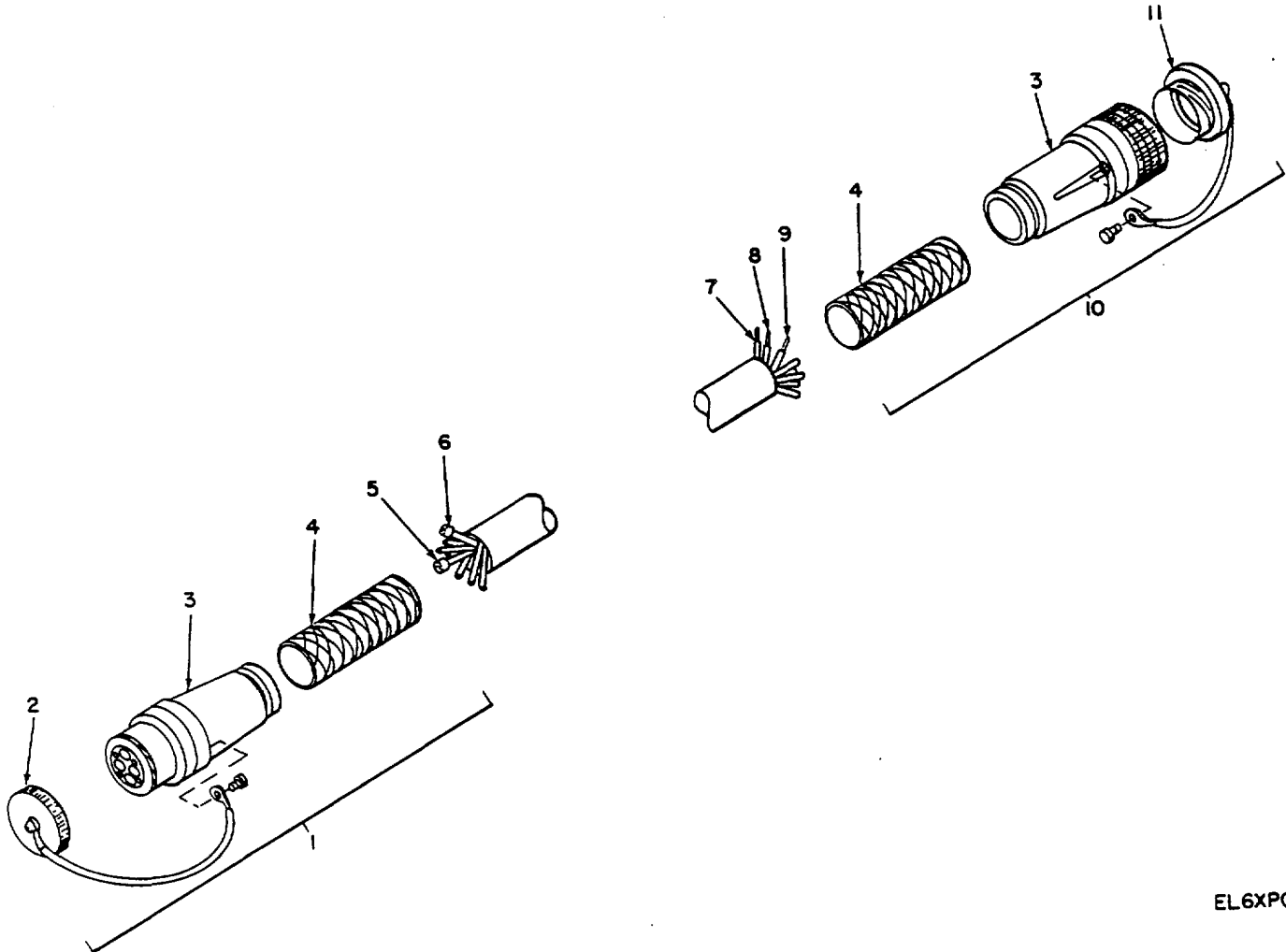

EL6XP016

Figure 8. Cable Assembly, Electrical Power.

SECTION II

TM 11-5410-216-24P

(1) ILLUSTRATION		(2)	(3)	(4)	(5)	(6)	(7)	(8)
(a) FIG NO.	(b) ITEM NO.	SMR CODE	NATIONAL STOCK NUMBER	FSCM	PART NUMBER	DESCRIPTION USABLE ON CODE	U/M	QTY INC IN UNIT
						GROUP 05 CABLE ASSEMBLY, ELECTRICAL POWER		
8	1	PAFZZ	5935-01-092-1037	96906	MS90557C44412S	CONNECTOR, PLUG, ELEC.....	EA	2
8	2	XDFZZ		96906	MS90563-70	COVER, ELEC.....	EA	2
8	3	PADZZ		96906	MS23747-15	GLAND, CABLE SEALIN.....	EA	2
8	4	PAFZZ		96906	MS90561-15	STRAIN RELIEF.....	EA	2
8	5	PAFZZ		96906	MS90560-3	CONTACT ELECTRICAL.....	EA	1
8	6	PAFZZ	5999-00-014-0952	96906	MS90560-7	CONTACT ELECTRICAL.....	EA	1
8	7	PAFZZ		96906	MS90559-11	CONTACT ELECTRICAL.....	EA	1
8	8	PAFZZ		96906	MS90559-5	CONTACT ELECTRICAL.....	EA	1
8	9	PAFZZ	5999-01-108-8602	96906	MS90559-14	CONTACT ELECTRICAL.....	EA	1
8	10	PAFZZ	5935-01-092-1038	96906	MS90556C44412P	CONNECTOR, PLUG, ELEC.....	EA	2
8	11	XDFZZ		96906	MS90564-70	COVER, ELEC.....	EA	2
					37			

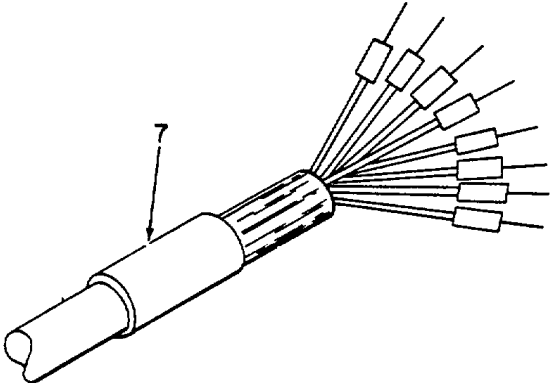
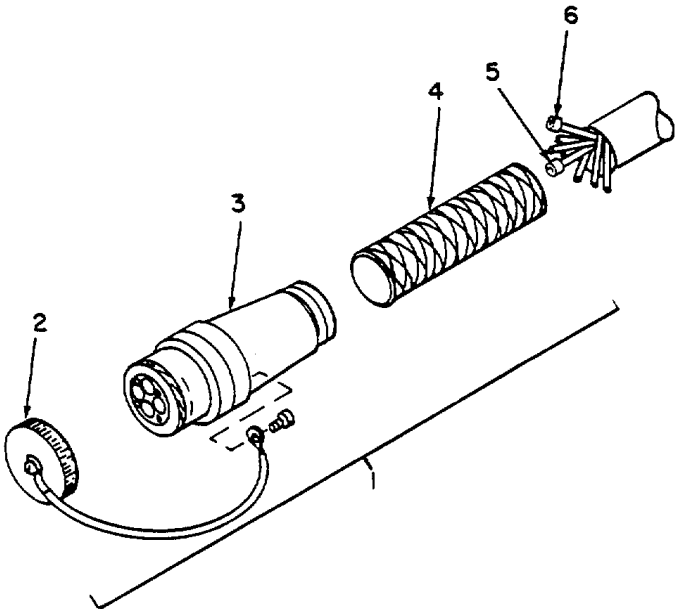

EL6XPO17

Figure 9. Cable Assembly, Electrical Power, Stub.

SECTION II

TM 11-5410-216-24P

(1) ILLUSTRATION		(2)	(3)	(4)	(5)	(6)	(7)	(8)
(a) FIG NO.	(b) ITEM NO.	SMR CODE	NATIONAL STOCK NUMBER	FSCM	PART NUMBER	DESCRIPTION USABLE ON CODE	U/M	QTY INC IN UNIT
						GROUP 06 CABLE ASSEMBLY, ELECTRICAL POWER, STUB		
9	1	PAFZZ	5935-01-092-1037	96906	MS90557C44412S	CONNECTOR, PLUG, ELEC.....	EA	1
9	2	XDFZZ		96906	MS90563-7C	COVER, ELEC.....	EA	1
9	3	PAOZZ		96906	MS23747-15	GLAND, CABLE, SEALIN.....	EA	1
9	4	PAFZZ		96906	MS90561-15	STRAIN RELIEF.....	EA	1
9	5	PAFZZ		96906	MS90560-3	CONTACT ELECTRICAL.....	EA	1
9	6	PAFZZ	5999-00-014-0952	96906	MS90560-7	CONTACT, ELECTRICAL L.....	EA	1
9	7	PADZZ		80063	SC-0-883964-8	END, SEAL.....	EA	1
39								

NATIONAL STOCK NUMBER AND PART NUMBER INDEX

NOTE: LATEST NATIONAL STOCK NUMBER AND PART NUMBER ASSIGNMENTS ARE INCLUDED AT END OF INDEX

STOCK NUMBER	FIG.	ITEM	STOCK NUMBER	FIG.	ITEM
5999-00-014-0952	8	6	6230-00-729-9614	2	81
5999-00-014-0952	9	6	6210-00-153-2289	6	14
5310-00-014-5850	1	3	6210-00-757-9694	3	3
5310-00-014-5850	4	5	5310-00-767-0445	3	85
5310-00-022-8834	3	450			
5310-00-045-3296	1	2	6250-00-804-3449	3	55
5310-00-045-3299	3	60	5310-00-807-1465	5	4
5310-00-045-4007	3	10	5310-00-809-3678	5	2
			5310-00-809-4058	2	14
5180-00-064-5178	2	33	5310-00-809-8544	3	65
5310-00-081-4219	1	7	5310-00-809-8544	3	16
6685-00-087-5499	2	3	5310-00-809-8544	4	3
5310-00-088-1251	5	3	5310-00-811-3494	4	2
5120-00-089-3663	2	62			
5940-00-114-1305	5	18	5310-00-836-2458	6	2
5110-00-115-5049	2	82	5305-00-842-0241	6	3
5305-00-137-3033	2	78	5315-00-844-3965	3	45G
5935-00-137-4819	5	12	5310-00-855-1102	3	45C
5940-00-143-4774	6	10	5310-00-877-5797	6	21
5940-00-143-4775	5	21	5999-00-879-6320	2	75
5310-00-146-7102	6	7	5310-00-880-5976	6	13
5930-00-148-8929	4	11	5310-00-883-9384	2	11
6240-00-152-2982	2	30			
6240-00-152-2996	2	72	1305-00-889-3001	5	9
6240-00-152-2996	3	62	5305-00-910-5363	6	1
6240-00-155-7786	2	88	6210-00-921-6682	3	64
7520-00-162-6178	2	68	5535-00-925-6396	6	5
7920-00-178-8315	2	86	5310-00-929-1807	1	12
5120-00-184-8443	2	57	5310-00-929-1807	2	8
5120-00-184-8447	2	55	5310-00-929-6395	6	12
5340-00-187-6023	3	36			
			5310-00-933-8121	1	23
6250-00-194-4794	2	71	5310-00-933-8121	1	35
5305-00-207-2297	3	27G	5310-00-933-8121	2	23
5120-00-240-8116	2	84	5210-00-933-8121	2	9
5310-00-245-3612	1	30	5310-00-933-8121	3	27F
5310-00-250-9477	2	93	5310-00-934-9751	1	1
5305-00-269-3220	1	6	5310-00-934-9766	3	45N
4210-00-270-4512	2	19	5120-00-942-3928	2	61
5120-00-277-8309	2	56	5310-00-942-5110	3	45M
6625-00-318-6304	1	48	5305-00-954-8152	3	45G
5310-00-400-5503	1	39	5 10-00-914-6623	1	20
6250-00-408-2639	3	52	5310-00-974-6623	2	11
5305-00-432-4170	2	21	5310-00-974-6623	2	101
5305-00-432-4206	3	37	5310-00-974-6623	3	33
6250-00-449-7859	3	59	5640-00-983-6086	6	8
5120-00-449-8083	2	60	5540-00-983-6122	3	87
5120-00-451-8250	2	85	5310-00-983-8483	2	19
6210-00-451-8350	3	74	5310-00-983-8483	5	5
5320-00-490-5523	5	7	5310-00-984-3806	1	9
5305-00-497-7410	2	a18	5305-00-984-4988	3	69
5305-00-517-6323	2	69	5205-00-984-4992	5	11
5805-00-543-0012	2	1	5205-00-984-6193	3	66
5306-00-543-4405	1	22	5305-00-984-6193	3	75
5310-00-550-5054	1	34	5305-00-984-6193	4	8
5310-00-550-5054	2	9	5310-00-984-7042	1	29
5930-00-570-5477	4	4	5305-00-988-1724	3	32
5305-00-576-5807	2	22	5305-00-989-6265	4	6
5310-00-582-5677	1	11	5305-00-993-2459	2	15
5310-00-582-5677	2	24	6250-00-995-9074	3	77
5310-00-582-5617	2	95	5830-01-008-3126	2	2
5310-00-582-5677	3	27E	5935-01-017-3290	5	8
5180-00-610-8177	2	34	5120-01-019-0803	2	63
5305-00-619-7712	2	80	5120-01-019-0812	2	65
5310-00-625-5756	2	12	5120-01-036-3728	2	4
5310-00-625-5756	2	102	5525-01-042-0109	3	15
5310-00-625-5756	3	84	5925-01-042-5012	3	16
5930-00-636-2726	3	11A	6350-01-044-2588	6	20
5306-00-637-9674	3	97	5970-01-050-4207	1	18
5306-00-637-9675	3	83	5970-01-050-4207	1	7
5310-00-680-6627	3	57A	5170-01-050-4207	2	51A
5930-00-683-1628	6	19	5310-01-052-5837	1	19
5305-00-685-3509	1	26	6625-01-060-6804	1	44
5305-00-685-3511	1	38	6625-01-069-4223	1	13
5925-00-686-3297	5	1	6240-01-072-2278	1	2
5305-00-702-4523	1	36	6210-01-073-5583	4	10
5940-00-703-9241	6	9	5515-01-073-6128	3	53
5305-00-719-5021	2	42	5935-01-092-1037	8	1
5306-00-727-4578	1	21	5535-01-092-1037	9	1
5306-00-727-4578	2	51	5935-01-092-1038	8	10

SECTION IV

TM 11-5410-216-24P

NATIONAL STOCK NUMBER AND PART NUMBER INDEX

STOCK NUMBER		FIG.	ITEM	STOCK NUMBER		FIG.	ITEM
5925-01-092-9573		3	14	6625-01-119-7314		1	43
7110-01-094-5655		2	20	5925-01-122-4739		3	39
6625-01-098-6956		1	10	5915-01-124-7031		3	28
6625-01-099-7065		1	40	6625-01-126-2473		1	47
6625-01-100-3726		1	45	5310-01-131-2247		3	45L
6135-01-103-6514		2	89	5995-01-133-9992		1	31
6210-01-106-6116		3	54	5995-01-134-3159		1	32
5999-01-108-8602		8	9	6135-01-134-6633		7	6
6210-01-110-2240		3	56	5595-01-134-6634		5	19
5120-01-110-9193		2	91				
FSCM	PART NUMBER	FIGURE NO.	ITEM NO.	FSCM	PART NUMBER	FIGURE NO.	ITEM NO.
81348	AA-C-00295C12S3	2	45	56996	84008466	2	77
80058	AN/USM-410(VI2	1	13	56996	84008467	2	41
80058	ANIUSM-451	1	44	56996	54008471	3	3
80058	AN/USM-465A	1	47	56996	84008474	3	19
88044	AN935-5	6	2	56996	54008477	5	15
11599	ATSQ3	2	60	56996	84008478	5	17
56996	84005327	1	28	56996	84008481	3	91
56996	84005338	1	17	56996	84008488	2	44
56996	84005342	1	15	56996	84008490	1	5
56996	84005343	1	16	56996	84008491	1	8
56996	84005347	1	14	56996	84008492	1	4
56996	84008032	3	40A	56996	84008506	3	86
56996	54008034	3	82	56996	84008575	3	10
56996	84008036	3	27H	56996	84008576-001	3	8
56996	84008038	3	270	56996	84008571-002	3	11
56996	84008041	2	53	56996	84008677	3	35A
56996	84008043-001	2	50	56996	84008677-002	J	45K
56996	84008043-002	2	49	56996	84008679-001	2	16
56996	84008107	3	44	56996	84008718	3	118
56996	84008109	2	40	56996	84008721	6	18
56996	84008117	3	27C	56996	84008722	6	15
56996	84008120	3	30	56996	84008725	6	6
56996	84008149	2	7	56996	84008726	2	96
56996	84008159	3	78	56996	84008734	3	45A
56996	84008160	3	49	56996	84008735	3	458
56996	84008161	3	71	56996	84008736	3	45E
56996	54008162	3	80	56996	84008737	3	45F
56996	40081169	3	48	56996	84008138	3	45P
56996	84008170	3	13	56996	84008745	2	92
56996	84008172	3	20	56996	84008746	2	99
56996	84008173-001	3	2	56996	84008747	2	108
56996	84008173-002	3	4	56996	84008748	2	109
56996	84]08173-003	3	46	56996	84008749	2	105
56996	84008173-004	3	5	56996	84008150	2	106
56996	84008173-005	3	6	56996	84008751	2	107
56996	84008173-008	3	47	56996	84008752	2	97
56996	84008174-001	3	67	56996	84008753	2	104
56996	84008178	3	17	56996	84008757	2	46
56996	84008239	3	79	56996	84008758	3	451
56996	84008240	3	58	56996	84008764	2	103
56996	84008241	3	72	56996	84008715	2	47
56996	84008260	5	6	56996	84008776	3	45J
56996	84008270	5	16	80538	CC-2-BHSRS-CP-M	2	6
56996	84008273	5	19	71468	CCT-DL	2	65
56996	84008280-001	3	88	11468	CET-DL-2	2	63
56996	54008321-003	3	90	81349	C-0440F-0665	3	23
56996	84008322-002	2	13	02777	F-3569	3	28
56996	84008347	3	50	08806	F15aTCW	2	30
56996	84008349	3	81	81348	GG-W-641TIP4L5	2	66
56996	84008355	3	31	81348	GGGW-.686TYP3CL2	2	67
56996	84008359	3	38	93101	HTA-L69	2	4
56996	84008361	2	26	81922	KAL36L100	3	39
56996	84008362	2	27	81349	LC22GD3	6	17
56996	84008363	2	28	81349	LC22RD3	6	16
56996	54008374	2	81	80058	LH80-1	6	14
56996	84008378	3	27	80058	LS-147F/FL	2	2
56996	84008390	3	40	65852	M-604	2	58
56996	84008405	3	9	80058	ME-521/USM4	1	40
56996	84008412	3	27A	80058	ME-525/USH	1	41
56996	84008418	2	43	80058	ME-526/USM	1	42
56996	84008425	3	22	81349	MIL-C-LI94TYPEA	2	74
56996	84008441	2	25	80058	MK-2046/MSM	1	10
56996	84008454	5	22	81349	MR36w200ACAAAR	4	7
				81349	MR36W300ACWR	4	9

NATIONAL STOCK NUMBER AND PART NUMBER INDEX

FSCM	PART NUMBER	FIGURE NO.	ITEM NO.	FSCM	PART NUMBER	FIGURE NO.	ITEM NO.
96906	MS15796-806	6	13	96906	MS35338-140	3	33
96906	MS15795-809	1	34	96906	MS35338-141	1	29
96906	MS15795-809	2	9	96906	MS35338-4	3	60
96906	MS15795-810	1	11	96906	MS35338-41	3	70
96906	MS15795-810	2	24	96906	MS35338-43	1	2
96906	MS15795-810	2	95	96906	MS35426-26	3	45C
96906	MS15795-810	3	27E	96906	MS3564-2254	2	93
96906	MS15795-812	2	12	96906	MS35649-2255	3	45C
96906	MS15795-812	2	102	96906	MS35644-2316	2	100
96906	MS15795-812	3	84	96906	MS35650-302	1	1
96906	MS15795-842	2	17	96906	MS35650-305	3	4
				96906	MS35650-3254	1	39
96909	MS16212-12	1	24	96906	MS35650-3384	1	30
96906	MS16562-48	3	45G	96906	MS51861-14	2	48
96906	MSI17143-5	6	9	96906	MS51861-17	2	76
96906	MS20365-1032A	6	21	96906	MS51861-27C	2	78
96906	MS21042-06	5	4	96906	MS51861-35	2	21
96906	MS21044NCB	4	2	96906	MS51861-39	2	5
96906	MS21122-6	3	36	96906	MS51861-39C	2	69
				96906	MS51861-50	3	37
96906	4S21783-5	3	68	96906	MS51861-51C	2	80
96906	MS73747-15	8	3				
96906	mS23747-15	9	3	96906	MS51861-53C	2	18
96906	MS24523-22	6	19	96906	MS51922-1	5	3
96906	MS25036-110	5	18	96906	MS51922-2	1	12
96906	MS25036-153	6	10	96906	MS51922-2	2	d
96906	MS25036-156	5	21	96906	MS51922-9	1	9
96906	MS25043-280	5	12	96906	MS51957-28	6	11
96906	MS25082-C1	6	7				
96906	MS25082-1	3	57A	96906	MS51959-81	2	42
96906	MS25244-5	5	1	96906	MS51971-2	3	85
96906	MS25324-4	6	5	96906	MS90556C4412P	5	10
96906	MS25332-1	6	1	96906	MS0557C44412S	8	1
96906	MS27130-43	1	25	96906	MS90557C44412S	9	1
96906	MS27183-10	2	14	96906	MS9G5SDC44412P	5	20
06906	MS27183-11	5	2	90906	MS90559-11	8	7
96906	MS27183-11	1	7	96906	MS90559-14	8	9
96906	MS27183-42	1	3	96906	MS90559-5	8	8
96906	MS27183-42	4	5	96906	MS90560-3	8	5
96906	MS271B3-5	2	19	96906	MS90560-3	9	5
96906	MS271B3-5	5	5	96906	MS90560-7	8	6
96906	MS27183-7	3	65	96906	MS90560-7	9	B
96906	MS2783-7	3	76	96906	MS90561-15	8	4
96906	MS27183-7	4	3	96906	MS90561-15	9	4
96906	MS305-12LA	3	25	96U06	MS90563-7C	A	2
96906	MS3108AE2-22S	3	26	96906	MS90563-7C	9	2
969C6	MS35206-228	3	69	96906	MS90564-7C	8	11
96906	MS35206-231	5	9	96906	M90725-70	1	6
96906	MS35206-23	5	11	80058	MX-1C314/USM	1	45
96906	MS35206-245	3	66	80058	M10	1	33
96906	MS35206-245	3	75	81349	M24066/2-304	2	75
96906	MS3206-245	4	8	81349	M24243/17-A6C6H	5	7
96906	MSJ5206-280	3	32	80205	NAS60-6	6	3
96906	MS35207-262	4	6	47805	PR0T03215	2	56
96906	MS35207-283	2	15	08806	PR2	2	8A
96906	MS35208-329	3	61	96508	PS120	2	62
96906	MS35214-61	3	45H	56996	SC-8-539492	2	39
96906	MS35215-59	3	450	80063	SC-8-539504	2	71
96906	MS35307-306	1	36	80063	SC-8-539568	3	52
96906	MS35307-31	2	22	80063	SC-8-681043	1	18
96906	MS35307-312	3	27G	80063	SC-8-681043	1	37
96906	MS35307-332	3	83	80063	SC-6-681043	2	51A
96906	MS35307-334	1	22	80063	SC-8-681044	1	19
96906	MS35307-336	3	97	80063	SC-C-539451	2	82
96906	MS35307-339	1	21	80063	SC-C-539466	3	64
96906	MS353C7-339	2	51	80063	SC-C-539466-1	3	74
96906	MS35308-306	1	38	80063	SC-C-539469	2	86
96906	MS35308-362	1	26	80063	SC-C-539495	2	72
96906	M535333-108	3	450	80063	SC-C-539495	3	62
96906	MS35335-88	3	45M	80063	SC-C-539498	3	63
96906	MS3533E-136	6	12	80063	SC-C-539502	2	85
				80063	SC-L-539503	2	68
96906	MS35338-13)9	1	23	80063	SC-C-539504	3	57
96906	MS35338-139	1	35	80063	SC-C-53952-1	2	10
96906	MS35338-139	2	23	80063	SC-C-539558	3	51
96906	MS35338-139	2	94	80063	SC-C-539759-1	3	92
96906	MS35338-139	3	27F	80063	SC-C-539894	2	84
96906	MS35338-140	1	20	80063	C50-681035	3	59
96906	MS35338-140	2	IT	80063	SC-C-681077-1	3	41
96906	MS35338-140	2	101	80063	SC-C-681077-6	3	43

SECTION IV

TM 11-5410-216-24P

NATIONAL STOCK NUMBER AND PART NUMBER INDEX

FSCM	PART NUMBER	FIGURE	ITEM	FSCM	PART NUMBER	FIGURE	ITEM
		NO.	NO.			NO.	NO.
80063	SC-C-681078-2	3	89	8L348	W5896/12-3A	3	1
80063	SC-C-681078-2	3	42	92578	W42AA-1	3	1
80063	SC-C-681078-3	3	21	80058	0S-261C7V)1/U	1	43
80063	S-C-681078-6	3	278	89942	01-222-H/7	2	38
80063	SC-C-68107S-7	3	45	74545	1C-37093-323	5	13
80063	SC-C-681092	5	10				
80063	SC-C-681183	3	54				
80063	SC-C-681184	3	56	65814	1114	2	57
80063	SC-C-681185	3	55	65814	1120	2	55
80063	S-C-681186	3	53	19207	116846J8	2	98
80063	SC-C-681207	3	77	52797	2A-5G5	4	10
80063	SC-C-681320-9	3	24	S2942	2064	2	36
80063	SC-C-681422	5	14	32532	2106-7	2	87
80063	SC--539482	2	19	82121	2405H	4	11
80063	SC-D-539551	2	20	82121	2410H	4	4
80063	SC-O-681425	2	83	08806	25T8OC	2	73
80063	SC-D-83963-G9-3	1	32	08806	2T80OC	3	73
80063	SC-O-883964-G9-2	1	31	81349	3ETB-8	6	8
80063	SC-O-883964-8	9	7	81345	35TB-2	3	07
06124	SC110M	6	20	02177	4.900.006-4	3	29
96508	SDX-22	2	64	70925	2S-10	2	61
80058	SG-1093/U	1	48	08806	60W	2	3
90303	SIZE D	2	89	80538	61os518	7	6
80063	SM-D-350218	2	35A	80538	610689-1	7	1
80058	TA-312/PT	2	1	80538	610689-3	7	3
80058	TK-101/G	2	33	80538	610652-1	7	5
80058	TK-105/G	2	34	80538	61C814	7	9
27319	T6051A1016	3	11A	80536	610815	7	8
80058	V-516(V11/MSM	1	46	33525	719730	7	7
81348	W-L-312TYPE3	2	29	33525	726016	7	4
81348	W-L-6611YPEICLZ	2	31	08806	7613	1	2
81348	WC375/01-002	3	15	76732	80-8	2	91
81348	WC375/02-004	3	14	53498	8C2-43U-KLLF	4	1
81348	WC375/03-005	3	16	76381	8210	2	37
81348	WC596/12-3	5	8	80112	9200	2	35
81348	WC596/L9-1	3	18	35344	9227-4455	6	4

LATEST NATIONAL STOCK NUMBER ASSIGNMENTSLATEST PART NUMBER ASSIGNMENTS

STOCK NUMBER	FIGURE	ITEM	FSCM	PART NUMBER	FIGURE	ITEM
	NO.	NO.			NO.	NO.
5305-00-059-3661	3	96	96306	BZ-2RQ18A2	3	12
5310-00-081-4219	3	34	56996	B4008079	2	52
5930-00-683-2703	3	12	56996	B4008119	3	35
5306-00-816-5272	2	20	56996	B4008480	3	93
5120-00-829-7691	2	54	96906	MS15795-842	3	94
5310-00-883-9384	3	94	96906	MS16212-13	1	27
5310-00-933-8120	3	95	96906	MS27183-12	3	34
5935-01-111-5568	3	7	96906	MS35307-340	2	10
			96906	MS35338-138	3	95
			96906	MS51958-652	3	96
			80058	M10	1	33
			65852	M-605	2	59
			89750	OE5-S	2	54
			80063	SC-D-14158	2	90
			81348	WC596712-2	3	7

43/(44 BLANK)

By Order of the Secretary of the Army:

JOHN A. WICKHAM, JR.
General, United States Army
Chief of Staff

Official:

ROBERT M. JOYCE
Major General, United States Army
The Adjutant General

Distribution:

To be distributed in accordance with Special List.

*U.S. GOVERNMENT PRINTING OFFICE: 1983-605-040/263

RECOMMENDED CHANGES TO EQUIPMENT TECHNICAL PUBLICATIONS



THEN... JOT DOWN THE DOPE ABOUT IT ON THIS FORM, CAREFULLY TEAR IT OUT, FOLD IT AND DROP IT IN THE MAIL!

SOMETHING WRONG WITH THIS PUBLICATION?

FROM: (PRINT YOUR UNIT'S COMPLETE ADDRESS)

DATE SENT

PUBLICATION NUMBER

PUBLICATION DATE

PUBLICATION TITLE

BE EXACT... PIN-POINT WHERE IT IS

PAGE NO.	PARA-GRAPH	FIGURE NO.	TABLE NO.
----------	------------	------------	-----------

IN THIS SPACE TELL WHAT IS WRONG AND WHAT SHOULD BE DONE ABOUT IT:

TEAR ALONG PERFORATED LINE

PRINTED NAME, GRADE OR TITLE, AND TELEPHONE NUMBER

SIGN HERE:

DA FORM 2028-2
1 JUL 79

PREVIOUS EDITIONS ARE OBSOLETE.

P.S.—IF YOUR OUTFIT WANTS TO KNOW ABOUT YOUR RECOMMENDATION MAKE A CARBON COPY OF THIS AND GIVE IT TO YOUR HEADQUARTERS.

PIN: 053085-000